



ALMA MATER STUDIORUM  
UNIVERSITÀ DI BOLOGNA



---

# The Biogeochemical Flux Model (BFM)

Equation Description and User Manual

BFM version 5.1

*The BFM System Team*

Release 1.1, August 2015

— BFM Report series N. 1 —

<http://bfm-community.eu>

[info@bfm-community.eu](mailto:info@bfm-community.eu)

---



This document should be cited as:

Vichi M., Lovato T., Lazzari P., Cossarini G., Gutierrez Mlot E., Mattia G., Masina S., McKiver W. J., Pinardi N., Solidoro C., Tedesco L., Zavatarelli M. (2015). The Biogeochemical Flux Model (BFM): Equation Description and User Manual. BFM version 5.1. BFM Report series N. 1, Release 1.1, August 2015, Bologna, Italy, <http://bfm-community.eu>, pp. 104

Copyright 2015, The BFM System Team. This work is licensed under the Creative Commons Attribution-Noncommercial-No Derivative Works 2.5 License. To view a copy of this license, visit <http://creativecommons.org/licenses/by-nc-nd/2.5/> or send a letter to Creative Commons, 171 Second Street, Suite 300, San Francisco, California, 94105, USA.

# Contents

<b>I. The BFM Equations</b>	<b>13</b>
<b>1. The formalism of the BFM equations</b>	<b>15</b>
<b>2. The pelagic plankton model</b>	<b>19</b>
2.1. The environmental parameters affecting biological rates . . . . .	19
2.2. Phytoplankton . . . . .	20
2.2.1. Photosynthesis and carbon dynamics . . . . .	22
2.2.2. Multiple nutrient limitation . . . . .	24
2.2.3. Nutrient uptake . . . . .	25
2.2.3.1. Nitrogen . . . . .	25
2.2.3.2. Phosphorus . . . . .	25
2.2.3.3. Silicate . . . . .	26
2.2.4. Nutrient loss associated with lysis . . . . .	26
2.2.5. Exudation of carbohydrates . . . . .	26
2.2.6. Chlorophyll synthesis and photoacclimation . . . . .	27
2.2.7. Light limitation and photoacclimation based on optimal light . . . . .	28
2.2.8. Iron in phytoplankton . . . . .	29
2.2.9. Phytoplankton sinking . . . . .	29
2.3. Bacterioplankton . . . . .	29
2.3.1. Regulating factors . . . . .	31
2.3.2. Respiration . . . . .	31
2.3.3. Mortality . . . . .	31
2.3.4. BACT1 parameterization . . . . .	33
2.3.4.1. Substrate uptake . . . . .	33
2.3.4.2. Nutrient release and uptake . . . . .	33
2.3.4.3. Excretion . . . . .	34
2.3.5. BACT2 parameterization . . . . .	34
2.3.5.1. Substrate uptake . . . . .	34
2.3.5.2. Nutrient release and uptake . . . . .	34
2.3.6. BACT3 parameterization . . . . .	34
2.3.6.1. Substrate uptake . . . . .	34
2.3.6.2. Nutrient release and uptake . . . . .	35
2.3.6.3. Excretion . . . . .	35
2.4. Zooplankton . . . . .	35
2.4.1. Food availability . . . . .	35
2.4.2. Ingestion . . . . .	37
2.4.3. Excretion/egestion . . . . .	37

## Contents

2.4.4. Respiration . . . . .	38
2.4.5. Excretion/egestion of organic nutrients . . . . .	39
2.4.6. Inorganic nutrients . . . . .	39
2.5. Non-living components . . . . .	40
2.5.1. Oxygen and anoxic processes . . . . .	40
2.5.2. Dissolved inorganic nutrients . . . . .	41
2.5.3. Dissolved and particulate organic matter . . . . .	43
2.5.4. The carbonate system . . . . .	44
<b>3. The sea ice biogeochemical model</b>	<b>49</b>
3.1. A model for sea ice biogeochemistry . . . . .	49
3.2. Model structure . . . . .	49
3.3. Sea ice Algae Dynamics . . . . .	50
3.4. Nutrient Supply and Dynamics . . . . .	55
3.5. Gases and Detritus . . . . .	56
3.6. The coupling strategy . . . . .	56
3.6.1. Boundary fluxes: the sea ice-ocean interface . . . . .	57
3.6.2. Boundary fluxes: the sea ice-atmosphere interface . . . . .	59
<b>II. BFM code description</b>	<b>61</b>
<b>4. Installation, configuration and compilation</b>	<b>63</b>
4.1. Installation . . . . .	63
4.1.1. System Requirements . . . . .	63
4.2. Configuration: BFM Presets . . . . .	65
4.3. Compiling the BFM STANDALONE . . . . .	67
<b>5. Running the STANDALONE model</b>	<b>69</b>
5.1. Description . . . . .	69
5.2. State variables initial conditions (IC) . . . . .	69
5.3. Numerical integration . . . . .	69
5.4. Forcing functions . . . . .	71
5.4.1. Analytical forcing functions . . . . .	71
5.4.2. Boundary forcing for atmospheric CO <sub>2</sub> . . . . .	73
5.4.3. Environmental data from file . . . . .	73
5.4.4. External event data . . . . .	73
5.5. Test cases . . . . .	73
5.5.1. STANDALONE_CO2TEST: carbonate system model . . . . .	73
5.5.2. STANDALONE_PELAGIC: the full pelagic BFM . . . . .	76
5.5.3. STANDALONE_SEAICE: sea ice biogeochemistry . . . . .	76
5.6. Output visualization . . . . .	76
<b>6. Structure of the code</b>	<b>81</b>
6.1. Coding rules . . . . .	81
6.2. Memory layout and variable definition . . . . .	81

6.3. The BFM flow-chart . . . . .	83
6.3.1. Initialization procedures . . . . .	83
6.3.2. Time marching . . . . .	84
6.3.3. Computation of pelagic reaction terms . . . . .	87
<b>7. Design model layout components</b>	<b>89</b>
7.1. Layout syntax and modular structure . . . . .	89
7.2. Example 1. Adding a subgroup . . . . .	92
7.3. Example 2. Adding a biochemical component and a group . . . . .	94
7.4. Example 3. Removing components from zooplankton . . . . .	95
<b>8. Model outputs</b>	<b>97</b>
8.1. Output . . . . .	97
8.2. Restart . . . . .	97
8.3. Aggregated diagnostics and rates . . . . .	97
8.4. Mass conservation . . . . .	99
<b>Bibliography</b>	<b>101</b>



# List of Equation Boxes

2.1. Phytoplankton . . . . .	21
2.2. Chlorophyll synthesis . . . . .	28
2.3. Bacteria . . . . .	33
2.4. Zooplankton . . . . .	36
2.5. Dissolved inorganic nutrient equations. . . . .	42
2.6. Dissolved organic matter . . . . .	43
2.7. Particulate organic detritus equations. . . . .	45
3.1. Sea ice algae . . . . .	54





# List of Tables

1.1. BFM reference state variables . . . . .	17
1.2. List of abbreviations . . . . .	18
2.1. Environmental variables . . . . .	21
2.2. Phytoplankton parameters . . . . .	23
2.3. Iron cycle parameters . . . . .	30
2.4. Bacterioplankton . . . . .	32
2.5. Microzooplankton . . . . .	36
2.6. Mesozooplankton . . . . .	37
2.7. Switches for mesozooplankton food limitation . . . . .	39
2.8. Chemical parameters . . . . .	42
2.9. Carbonate system . . . . .	47
3.1. List of the sea ice model state variables . . . . .	52
3.2. Ecological and physiological parameters in BFM-SI. . . . .	53
4.1. List of optional arguments for bfm_configure . . . . .	68
5.1. namelist bfm_nml in BFM_General.nml . . . . .	70
5.2. namelist Param_parameters in BFM_General.nml . . . . .	70
5.3. namelist PAR_parameters in Pelagic_Environment.nml . . . . .	71
5.4. namelist standalone_nml in Standalone.nml . . . . .	72
5.5. namelist time_nml in Standalone.nml . . . . .	72
5.6. namelist forcings_nml in Standalone.nml . . . . .	74
7.1. Example of model layout . . . . .	90



# Introduction

## Synopsis

This report is divided in two main parts. The first part contains an extended description of the Biogeochemical Flux Model (BFM version 5) equations and as such it describes different parameterizations that can be used to simulate biogeochemical processes in the marine system. Part II describes the model set-up, compilation and execution of the standard test cases. It also provides the major technical implementation of the model and information to understand the code structure. This part gives examples of the possible diagnostics that can be activated and illustrates advanced features that allow the user to modify the model adding new state variables and components.

The BFM is a direct descendant of the European Regional Seas Ecosystem Model (ERSEM) and shares most of its characteristics with the original formulations (Baretta et al., 1995; Baretta-Bekker et al., 1997). The major difference is that BFM focuses more on the biogeochemistry of lower trophic levels in marine ecosystems than on trophic food webs, which is where it takes its name. The philosophy of the BFM and the mathematical formulation applied throughout the book are described in Vichi et al. (2007b). The users familiar with ERSEM will find that the code notation described by Blackford and Radford (1995) has not changed substantially and that the state variables are indicated with the same naming convention. Vichi et al. (2007b) have extended this notation making it formally consistent and additional variables have been named accordingly.

The structure of the code was instead extensively modified with respect to the original ERSEM code. The major reason for a full rewriting lied in the growing need to couple biogeochemical processes with hydrodynamical model of various forms and to allow a modular expan-

sion of the number and type of state variables in modern coding standards. The necessity to have a flexible system which can be embedded in the existing state-of-the-art ocean general circulation models (OGCM) required a re-organization of the structure, yet the fundamentals of the coupling strategy are very similar to the first coupled implementations. From BFM version 5.1 the coupled configurations are publicly supported. The BFM module can be easily coupled with different ocean models and an example of the coupled configuration with the NEMO ocean model (<http://nemo-ocean.eu>) is given in the companying manual of this release Vichi et al. (2015).

## The BFM module

This report documents the BFM equations for the standalone pelagic configuration of the code that solves the reaction part of the general equations for biogeochemical tracers in the marine environment. The state variables presented in Part I are historically derived from the pelagic component of ERSEM and represent the standard set of transformations for the major chemical constituents. The BFM by construction solves the cycles of C, O, N, P, Si in the lower trophic levels of marine ecosystems and it also allows the inclusion of the Fe cycle and carbonate system chemistry by means of user-controlled flags. Different parameterizations are proposed for the various functional groups as they have been demonstrated valid in certain model applications. Given the inherent empirical nature of biogeochemical modeling, the proposed parameterizations are given “as they are” and it is up to the user to decide which one to use given the specific application. The modular implementation of the BFM allows to implement new parameterizations and new state variables.

## List of Tables

The equations of Part I consider no vertical or horizontal processes and the system is solved as a set of ordinary differential equations. At the heart of the BFM module is the possibility to increase the number of components, as for instance implementing any number of phytoplankton groups that share the same dynamical terms but differ in term of parameter and parameterization choices. The user interested in this feature, in the modification of the model layout and in the definition of specific diagnostics will find in Part II all the required information. The reference test cases will be presented in the STANDALONE implementation, which is a time-dependent box model with a given depth where pelagic processes are assumed homogeneous.

## Licensing

The BFM is free software and is protected by the GNU Public License <http://www.gnu.org/licenses/gpl.html>. All files of the BFM contain the following statement:

Copyright 2013, The BFM System Team (info@bfm-community.eu)  
<Past Copyrights>  
This file is part of the BFM.  
The BFM is free software: you can re-

distribute it and/or modify it under the terms of the GNU General Public License as published by the Free Software Foundation, either version 3 of the License, or (at your option) any later version. The BFM is distributed in the hope that it will be useful, but WITHOUT ANY WARRANTY; without even the implied warranty of MERCHANTABILITY or FITNESS FOR A PARTICULAR PURPOSE. See the GNU General Public License for more details. You should have received a copy of the GNU General Public License along with the BFM core. If not, see <<http://www.gnu.org/licenses/>>.

## Acknowledgments

The code support and development is currently done by the BFM System Team whose members are listed on the BFM web site (<http://bfm-community.eu>). The initial core of the BFM system software was developed by Piet Ruardij and Marcello Vichi. The BFM system team is grateful to Job Baretta, Hanneke Baretta-Bekker, Piet Ruardij and Wolfgang Ebenhoeh for their contribution to the science of biogeochemical modeling.

**Part I.**

# **The BFM Equations**



# 1. The formalism of the BFM equations

The BFM equations are written following the notation proposed by Vichi et al. (2007b), which is briefly summarized in this section. The reader is referred to Vichi et al. (2007b) for a more theoretical viewpoint on the extension of the ERSEM approach to the system state variables of the plankton ecosystem. As shown in Tab. 1.1, each variable is mathematically expressed by a multi-dimensional array that contains the concentrations of reference chemical constituents. We use a superscript indicating the CFF for a specific living functional group and a subscript for the basic constituent. For instance, diatoms are LFG of producers and comprise 6 living CFFs written as

$$P_i^{(1)} \equiv (P_c^{(1)}, P_n^{(1)}, P_p^{(1)}, P_s^{(1)}, P_f^{(1)}, P_l^{(1)}).$$

The standard model resolves 4 different groups for phytoplankton  $P^{(j)}$ ,  $j = 1, 2, 3, 4$  (diatoms, autotrophic nanoflagellates, picophytoplankton and large phytoplankton), 4 for zooplankton  $Z^{(j)}$ ,  $j = 3, 4, 5, 6$  (carnivorous and omnivorous mesozooplankton, microzooplankton and heterotrophic nanoflagellates), 1 for bacteria, 7 inorganic variables for nutrients and gases (phosphate, nitrate, ammonium, silicate, reduction equivalents, oxygen, carbon dioxide) and 10 organic non-living components for dissolved and particulate detritus (cf. Tab. 1.1 and Fig. 1.1). The state variable nitrate is assumed here to be the sum of both nitrate and nitrite. Reduction equivalents represent all the reduced ions produced under anaerobic conditions. This variable was originally used only in the benthic nutrient regeneration module of ERSEM (Ruardij and Van Raaphorst, 1995) but was extended to the water column in Vichi et al. (2004). In this approach, all the nutrient-carbon and chlorophyll-carbon ratios are allowed to vary

within their given ranges and each component has a distinct biological time rate of change.

Following Vichi et al. (2007b) the dynamical equations are written in two forms: 1) rates of change form; and 2) explicit functional form. In “rates of change form”, the biogeochemical reaction term a generic state variable  $C$  is written as:

$$\left. \frac{dC}{dt} \right|_{bio} = \sum_{i=1,n} \sum_{j=1,m} \left. \frac{dC}{dt} \right|_{V_i}^{e_j}, \quad (1.0.1)$$

where the right hand side contains the terms representing significant processes for each living or non-living component. The superscripts  $e_j$  are the abbreviations indicating the process which determines the variation. In Table 1.2 we report the acronyms of the processes used in the superscripts. The subscripts  $V_i$  indicate the state variable involved in the process. If  $V = C$ , we refer to intra-group interactions such as cannibalism.

When a term is present as a source in one equation and as a sink in another, we refer to it following this equivalent notation:

$$\left. \frac{dC}{dt} \right|_V^e = - \left. \frac{dV}{dt} \right|_C^e. \quad (1.0.2)$$

In “functional process form”, the formulation of the dynamic dependencies on other variables is made explicit, *i.e.*: all the rates of change in eq. (1.0.1) are given in the complete functional parameterization. Although this is the more complete mathematical form, it is more difficult to read and interpret at a glance, especially when trying to distinguish which processes affect the dynamics of which variable. All equations in this Part will be presented both in rate of change and in functional process forms.

1. The formalism of the BFM equations

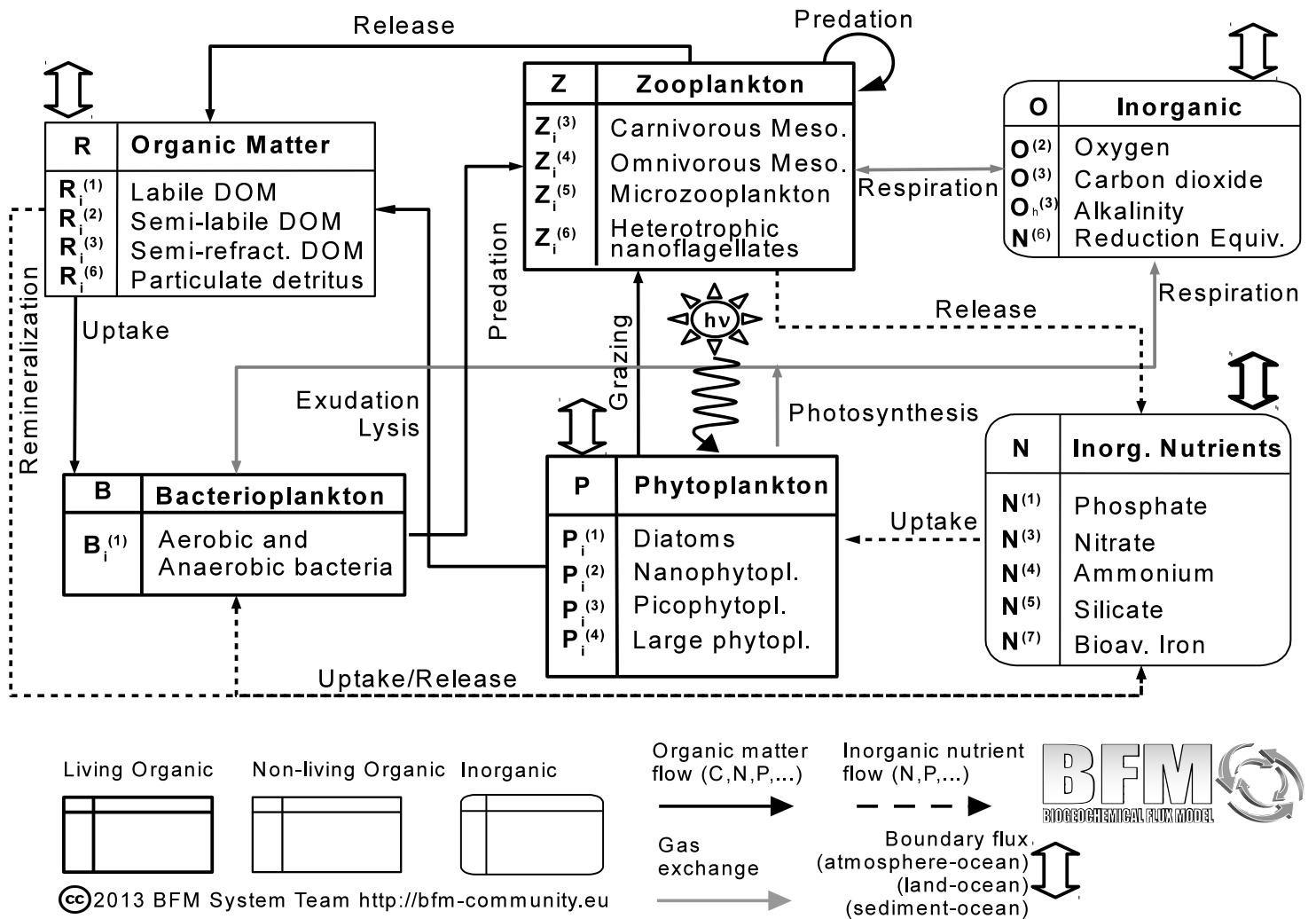

Figure 1.1.: Scheme of the state variables and pelagic interactions of the reference STANDALONE model. Living components are indicated with bold-line square boxes, non-living organic components with thin-line square boxes and inorganic components with rounded boxes (modified after Blackford and Radford (1995) and Vichi et al. (2007b)).



Variable	Code	Type	Const.	Units	Description
$N^{(1)}$	N1p	IO	P	mmol P m <sup>-3</sup>	Phosphate
$N^{(3)}$	N3n	IO	N	mmol N m <sup>-3</sup>	Nitrate
$N^{(4)}$	N4n	IO	N	mmol N m <sup>-3</sup>	Ammonium
$N^{(5)}$	N5s	IO	Si	mmol Si m <sup>-3</sup>	Silicate
$N^{(6)}$	N6r	IO	R	mmol S m <sup>-3</sup>	Reduction equivalents, HS <sup>-</sup>
$N^{(7)}$	N7f	IO	Fe	$\mu$ mol Fe m <sup>-3</sup>	Dissolved Iron
$O^{(2)}$	O2o	IO	O	mmol O <sub>2</sub> m <sup>-3</sup>	Dissolved Oxygen
$O^{(3)}$	O3c	IO	C	mg C m <sup>-3</sup>	Dissolved Inorganic Carbon
$O^{(5)}$	O3h	IO	-	mmol Eq m <sup>-3</sup>	Total Alkalinity
$P_i^{(1)}$	P1[cnpslf]	LO	C N P Si Chl Fe	mg C m <sup>-3</sup> , mmol N-P-Si m <sup>-3</sup> , mg Chl- <i>a</i> m <sup>-3</sup> , $\mu$ mol Fe m <sup>-3</sup>	Diatoms
$P_i^{(2)}$	P2[cnplf]	LO	C N P Chl Fe	mg C m <sup>-3</sup> , mmol N-P m <sup>-3</sup> , mg Chl- <i>a</i> m <sup>-3</sup> , $\mu$ mol Fe m <sup>-3</sup>	NanoFlagellates
$P_i^{(3)}$	P3[cnplf]	LO	C N P Chl Fe	mg C m <sup>-3</sup> , mmol N-P m <sup>-3</sup> , mg Chl- <i>a</i> m <sup>-3</sup> , $\mu$ mol Fe m <sup>-3</sup>	Picophytoplankton
$P_i^{(4)}$	P4[cnplf]	LO	C N P Chl Fe	mg C m <sup>-3</sup> , mmol N-P m <sup>-3</sup> , mg Chl- <i>a</i> m <sup>-3</sup> , $\mu$ mol Fe m <sup>-3</sup>	Large phytoplankton
$B_i$	B1[cnp]	LO	C N P	mg C m <sup>-3</sup> , mmol N-P m <sup>-3</sup>	Pelagic Bacteria
$Z_i^{(3)}$	Z3[cnp]	LO	C N P	mg C m <sup>-3</sup> , mmol N-P m <sup>-3</sup>	Carnivorous Mesozooplankton
$Z_i^{(4)}$	Z4[cnp]	LO	C N P	mg C m <sup>-3</sup> , mmol N-P m <sup>-3</sup>	Omnivorous Mesozooplankton
$Z_i^{(5)}$	Z5[cnp]	LO	C N P	mg C m <sup>-3</sup> , mmol N-P m <sup>-3</sup>	Microzooplankton
$Z_i^{(6)}$	Z6[cnp]	LO	C N P	mg C m <sup>-3</sup> , mmol N-P m <sup>-3</sup>	Heterotrophic Flagellates
$R_i^{(1)}$	R1[cnpf]	NO	C N P Fe	mg C m <sup>-3</sup> , mmol N-P m <sup>-3</sup> , $\mu$ mol Fe m <sup>-3</sup>	Labile Dissolved Organic Matter
$R_c^{(2)}$	R2c	NO	C	mg C m <sup>-3</sup>	Semi-labile Dissolved Organic Carbon
$R_i^{(3)}$	R3c	NO	C	mg C m <sup>-3</sup>	Semi-refractory Dissolved Organic Carbon
$R_i^{(6)}$	R6[cnpsf]	NO	C N P Si Fe	mg C m <sup>-3</sup> , mmol N-P-Si m <sup>-3</sup> , $\mu$ mol Fe m <sup>-3</sup>	Particulate Organic Detritus

Table 1.1.: List of the reference state variables for the pelagic model. Type legend: IO = Inorganic; LO = Living organic; NO = Non-living organic. The subscript  $i$  indicates the basic components (if any) of the variable, e.g.  $P_i^{(1)} \equiv (P_c^{(1)}, P_n^{(1)}, P_p^{(1)}, P_s^{(1)}, P_l^{(1)}, P_f^{(1)})$ .

1. The formalism of the BFM equations

<b>Abbreviation</b>	<b>Process</b>
<i>gpp</i>	Gross primary production
<i>rsp</i>	Respiration
<i>prd</i>	Predation
<i>rel</i>	Biological release: Egestion, Excretion
<i>exu</i>	Exudation
<i>lys</i>	Lysis
<i>syn</i>	Biochemical synthesis
<i>nit/denit</i>	Nitrification, denitrification
<i>scv</i>	Scavenging
<i>rmn</i>	Biochemical remineralization

Table 1.2.: List of all the abbreviations used to indicate the physiological and ecological processes in the equations

## 2. The pelagic plankton model

### 2.1. The environmental parameters affecting biological rates

This section describes the dependencies of the pelagic biogeochemical processes from the physical environment. The BFM has defined a set of environmental variables that are provided by external data or by a physical model (Tab.2.1). The local coupling between physics and biogeochemistry is realized explicitly through surface irradiance and temperature. Temperature regulates all physiological processes in the model and its effect, denoted by  $f^T$ , is parameterized in this non-dimensional form

$$f^T = Q_{10}^{\frac{T-10}{10}} \quad (2.1.1)$$

where the  $Q_{10}$  coefficient is different for each functional process considered.

Light is fundamental for primary producers and the energy source for photosynthesis is the downwelling amount of the incident solar radiation at the sea surface. Only a portion of the downwelling irradiance is used for growth, the Photosynthetic Available Radiation (PAR)  $E_{PAR}$  (the notation of Sakshaug et al. (1997) is used here). The BFM only computes the propagation of PAR as a function of the attenuation coefficient of sea water, which is determined by the concentration of suspended and dissolved components. The BFM considers two cases controlled by the parameters described in Tab.5.3: 1) a broadband mean attenuation coefficient and 2) a 3-band attenuation coefficient for chlorophyll as proposed by Morel (1988) and tabulated according to Lengaigne et al. (2007).

In the default case we assume that PAR is propagated according to the Lambert-Beer formulation with broadband, depth-dependent extinction coefficients

$$E_{PAR}(z) = \varepsilon_{PAR} Q_S e^{\lambda_w z + \int_z^0 \lambda_{bio}(z') dz'} \quad (2.1.2)$$

where  $\varepsilon_{PAR}$  is the coefficient determining the fraction of PAR in  $Q_S$ . Light propagation takes into account the extinction due to suspended particles,  $\lambda_{bio}$ , and  $\lambda_w$  as the background extinction of water. The biological extinction is written as

$$\lambda_{bio} = \sum_{j=1}^4 c_{p(j)} P_l^{(j)} + c_{R(6)} R_c^{(6)} \quad (2.1.3)$$

where the extinctions due to the concentration of phytoplankton chlorophyll and particulate detritus are considered (see Sec. 2.2 and 2.5). The  $c$  constants are the specific absorption coefficients of each suspended substance (Tab. 2.2 and 2.8), which may also include extinction by suspended sediments (not currently resolved by the BFM but can be included from an external model).

With the 4-band wavelength parameterization the model considers differential attenuation of light divided in red, green and blue coefficients (RGB) that are functions of the chlorophyll concentration. The visible portion is divided equally in the 3 bands such as

$$E_{PAR}(z) = \frac{\varepsilon_{PAR}}{3} Q_S \left( e^{\int_z^0 \lambda_R(Chl,z') dz'} + e^{\int_z^0 \lambda_G(Chl,z') dz'} + e^{\int_z^0 \lambda_B(Chl,z') dz'} \right) \quad (2.1.4)$$

where the  $\lambda$  coefficients are obtained with a look-up table depending on the local total chlorophyll concentration  $Chl = \sum_{j=1}^4 P_l^{(j)}$ . In this parameterization both the background attenuation of water and the specific attenuation of chlorophyll are not used.

The short-wave surface irradiance flux  $Q_S$  is obtained generally from data or from an atmospheric radiative transfer model. Three types of forcings are allowed depending on the value of `LightPeriodFlag` in `Pelagic_Environment.nml`:

## 2. The pelagic plankton model

1. Instantaneous irradiance (LightPeriodFlag=1)
2. Daily average (LightPeriodFlag=2)
3. Daylight average (with explicit photoperiod, LightPeriodFlag=3)

The discretized irradiance  $E_{PAR}^k$  is located at the top of each layer  $k$ , and three different choices are available according to the parameter `LightLocationFlag` in `Pelagic_Ecology.nml`:

1. light at the upper interface  $E_{PAR} = E_{PAR}^k$  (LightLocationFlag=1),
2. light in the middle of the cell as in Lazzari et al. (2012) (LightLocationFlag=2),

$$E_{PAR} = E_{PAR}^k \exp\left(-\lambda^k \frac{\Delta z^k}{2}\right) \quad (2.1.5)$$

3. integrated light over the level depth as in Vichi et al. (2007b) (LightLocationFlag=3),

$$E_{PAR} = \frac{E_{PAR}^k}{\lambda^k \Delta z^k} \left(1 - \exp\left(-\lambda^k \Delta z^k\right)\right) \quad (2.1.6)$$

When needed for physiological computations, the value is converted from  $W\ m^{-2}$  to the unit of  $\mu E\ m^{-2}\ s^{-1}$  with the constant factor 1/0.215 (Reinart et al., 1998).

## 2.2. Phytoplankton

Primary producers are divided in four principal sub-groups coarsely representing the functional spectrum of phytoplankton in marine systems. The operational model definitions of the phytoplankton groups are:

- diatoms ( $P_i^{(1)}$ ), ESD = 20-200 $\mu$ , unicellular eukaryotes enclosed by a silica frustule eaten by micro- and mesozooplankton;

- autotrophic nanoflagellates ( $P_i^{(2)}$ ), ESD = 2-20 $\mu$ , motile unicellular eukaryotes comprising smaller dinoflagellates and other autotrophic microplanktonic flagellates eaten by heterotrophic nanoflagellates, micro- and mesozooplankton;

- picophytoplankton ( $P_i^{(3)}$ ), ESD = 0.2-2 $\mu$ , prokaryotic organism generally indicated as non-diazotrophic autotrophic bacteria such as *Prochlorococcus* and *Synechococcus*, but also mixed eukaryotic species (Worden et al., 2004), mostly preyed by heterotrophic nanoflagellates;

- large, slow-growing phytoplankton ( $P_i^{(4)}$ ), ESD > 100 $\mu$ , that represents a wide group of phytoplankton species, also comprising larger species belonging to the previous groups (for instance dinoflagellates) but also those that during some period of the year develop a form of (chemo)defense to predator attack. This group generally has low growth rates and small food matrix values with respect to micro- and mesozooplankton groups.

The processes parameterized in the biological source term are gross primary production (*gpp*), respiration (*rsp*), exudation (*exu*), cell lysis (*lys*), nutrient uptake (*upt*), predation (*prd*) and biochemical synthesis (*syn*). All the phytoplankton groups share the same form of primitive equations, but are differentiated in terms of the values of the physiological parameters.

Phytoplankton in the model is composed of several constituents and the related dynamical equations (Box 2.1): some of them are mandatory (C, N, P), that is they are required to compute physiological terms, and some others are required for specific groups (like Si in diatoms) or they are optional such as the Chl and Fe constituents. The inclusion of Fe is a typical example of the model flexibility as it allows to have an additional multiple-nutrient limitation term without affecting the other parameterizations (see Sec. 2.2.8).

When Chl constituent is not used (see Sec. 2.2.7), light acclimation in phytoplankton can be

<i>Symbol</i>	Code	Unit	Description
$T$	ETW	$^{\circ}\text{C}$	Sea water salinity
$S$	ESW	(-)	Sea water temperature
$\rho$	ERHO	$\text{Kg m}^{-3}$	Sea water density
$E_{PAR}$	EIR	$\mu\text{E m}^{-2}\text{s}^{-1}$	Photosynthetically available radiation
$S_S$	ESS	$\text{g m}^{-3}$	Suspended sediment load
$W_{atm}$	EWIND	$\text{m s}^{-1}$	Wind speed
$F_{ice}$	EICE	(-)	Sea ice fraction
$\Phi$	SUNQ	hours	Daylight length

Table 2.1.: Mathematical and code symbols, units and description of the environmental state variables defined in the model.

---

**Equation Box 2.1** Phytoplankton equations

---

$$\left. \frac{dP_c}{dt} \right|_{bio} = \left. \frac{dP_c}{dt} \right|_{O^{(3)}}^{gpp} - \left. \frac{dP_c}{dt} \right|_{R_c^{(2)}}^{exu} - \left. \frac{dP_c}{dt} \right|_{O^{(3)}}^{rsp} - \sum_{j=1,6} \left. \frac{dP_c}{dt} \right|_{R_c^{(j)}}^{lys} - \sum_{k=4,5,6} \left. \frac{dP_c}{dt} \right|_{Z_c^{(k)}}^{prd} \quad (2.2.1a)$$

$$\left. \frac{dP_n}{dt} \right|_{bio} = \sum_{i=3,4} \left. \frac{dP_n}{dt} \right|_{N^{(i)}}^{upt} - \sum_{j=1,6} \left. \frac{dP_n}{dt} \right|_{R_n^{(j)}}^{lys} - \frac{P_n}{P_c} \sum_{k=4,5,6} \left. \frac{dP_c}{dt} \right|_{Z_c^{(k)}}^{prd} \quad (2.2.1b)$$

$$\left. \frac{dP_p}{dt} \right|_{bio} = \left. \frac{dP_p}{dt} \right|_{N^{(1)}}^{upt} - \sum_{j=1,6} \left. \frac{dP_p}{dt} \right|_{R_p^{(j)}}^{lys} - \frac{P_p}{P_c} \sum_{k=4,5,6} \left. \frac{dP_c}{dt} \right|_{Z_c^{(k)}}^{prd} \quad (2.2.1c)$$

$$\left. \frac{dP_l}{dt} \right|_{bio} = \left. \frac{dP_l}{dt} \right|^{syn} - \frac{P_l}{P_c} \sum_j \left. \frac{dP_c}{dt} \right|_{Z_c^{(j)}}^{prd} \quad (2.2.1d)$$

$$\left. \frac{dP_s}{dt} \right|_{bio} = \left. \frac{dP_s}{dt} \right|_{N^{(5)}}^{upt} - \left. \frac{dP_s}{dt} \right|_{R_s^{(6)}}^{lys} - \frac{P_s}{P_c} \sum_{k=4,5,6} \left. \frac{dP_c}{dt} \right|_{Z_c^{(k)}}^{prd} \quad (2.2.1e)$$

$$\text{if } P_s \exists, \text{ otherwise } \left. \frac{dP_s}{dt} \right|_{bio} = 0$$

$$\left. \frac{dP_f}{dt} \right|_{bio} = \left. \frac{dP_f}{dt} \right|_{N^{(7)}}^{upt} - \left. \frac{dP_f}{dt} \right|_{R_f^{(6)}}^{lys} - \frac{P_f}{P_c} \sum_j \left. \frac{dP_c}{dt} \right|_{Z_c^{(j)}}^{prd} \quad (2.2.1f)$$

$$\text{if } P_f \exists, \text{ otherwise } \left. \frac{dP_f}{dt} \right|_{bio} = 0 \quad (2.2.1g)$$

---

## 2. The pelagic plankton model

described by means of the optimal light property as proposed by Ebenhöh et al. (1997). The notation remains mostly unchanged but in this case the variable  $\hat{P}_l$  indicates the optimal light level to which phytoplankton is acclimated and the alternative equation to (2.2.1d) is given in Sec. 2.2.7.

### 2.2.1. Photosynthesis and carbon dynamics

Photosynthesis is primarily controlled by light by means of the non-dimensional light regulation factor proposed by Jassby and Platt (1976)

$$f_P^E = 1 - \exp\left(-\frac{E_{PAR}}{E_K}\right) \quad (2.2.2)$$

where  $E_K$  is the optimal irradiance, defined as

$$\begin{aligned} E_k &= P_m^* / \alpha^* \\ P_m^* &= f_P^T f_P^{PP} r_P^0 \frac{P_c}{P_l} \\ \alpha^* &= f_P^T f_P^{PP} \alpha_{chl}^0 \end{aligned} \quad (2.2.3)$$

The maximum chl-specific photosynthetic rate  $P_m^*$  is controlled by the non-storable nutrients that control primary production  $f_P^{PP}$  (Sec. 2.2.2). It is assumed that both  $\alpha^*$  and  $P_m^*$  are controlled by the same regulating factors (Jassby and Platt, 1976; Behrenfeld et al., 2004). When instantaneous light is used, the equation is written in the following form:

$$f_P^E = 1 - \exp\left(-\frac{\alpha_{chl}^0 E_{PAR} P_l}{r_P^0 P_c}\right) \quad (2.2.4)$$

while in case the length of the photoperiod is considered, this is implicitly done in  $P_m^*$  that becomes.

$$P_m^* = f_P^T f_P^{PP} r_P^0 \frac{P_c}{P_l} \frac{\Phi}{24} \quad (2.2.5)$$

where  $\Phi$  is the daylight length in hours (Lazzari et al., 2012). The final form of gross primary production also depends on the choice of the daylight availability. In the case of instantaneous or average daily irradiance (Vichi et al., 2007a), it is written as

$$\frac{dP_c}{dt} \Big|_{O(3)}^{gPP} = f_P^T f_P^E f_P^{PP} r_P^0 P_c. \quad (2.2.6)$$

Note that it is possible to further control temperature limitation with a cut-off value  $c_P^T$  applied to the temperature regulating factor as done in (Vichi et al., 2007a) to control the growth of picophytoplankton at high latitudes:

$$f_P^T = \max(0, f_P^T - c_P^T). \quad (2.2.7)$$

Respiration is defined as the sum of the basal respiration, which is independent of the production rate, and the activity respiration:

$$\frac{dP_c}{dt} \Big|_{O(3)}^{rsp} = b_P f_P^T P_c + \gamma_P \frac{dP_c}{dt} \Big|_{O(3)}^{gPP}. \quad (2.2.8)$$

Basal respiration is only a function of the carbon biomass, temperature (through the regulating factor  $f_P^T$ ) and the specific constant rate  $b_P$ . The activity respiration is a constant fraction ( $\gamma_P$ ) of the total gross primary production.

The term lysis includes all the non-resolved mortality processes that disrupt the cell membrane, such as mechanical causes, virus and yeasts. It is assumed that the lysis rate is partitioned between particulate and dissolved detritus and tends towards the maximum specific rate  $d_P^0$  with a saturation function of the nutrient stress as:

$$\frac{dP_c}{dt} \Big|_{R_c^{(6)}}^{lys} = \varepsilon_P^{n,p} \left( \frac{h_P^{p,n}}{f_P^{p,n} + h_P^{p,n}} d_P^0 P_c + \chi^{lys} \right) \quad (2.2.9)$$

$$\frac{dP_c}{dt} \Big|_{R_c^{(1)}}^{lys} = \left( 1 - \varepsilon_P^{n,p} \right) \left( \frac{h_P^{p,n}}{f_P^{p,n} + h_P^{p,n}} d_P^0 P_c + \chi^{lys} \right) \quad (2.2.10)$$

The lysis of cells generates both dissolved and particulate detritus; the structural parts of the cell are not as easily degradable as the cytoplasm, therefore the percentage going to DOC is inversely proportional to the internal nutrient content and constrained by the minimum structural content in the following way:

$$\varepsilon_P^{n,p} = \min\left(1, \frac{P_P^{min}}{P_P/P_c}, \frac{n_P^{min}}{P_n/P_c}\right). \quad (2.2.11)$$

## 2.2. Phytoplankton

Symbol	Code	Unit	Description
$Q_{10p}$	p_q10	-	Characteristic Q10 coefficient
$c_p^T$	p_temp	-	Cut-off threshold for temperature regulating factor
$r_{0p}$	p_sum	$d^{-1}$	Maximum specific photosynthetic rate
$b_p$	p_srs	$d^{-1}$	Basal specific respiration rate
$d_{0p}$	p_sdmo	$d^{-1}$	Maximum specific nutrient-stress lysis rate
$h_p^{p,n,s}$	p_thdo	-	Nutrient stress threshold
$d_p^x$	p_seo	$d^{-1}$	Extra lysis rate
$h_p^x$	p_sheo	$mg\ C\ m^{-3}$	Half saturation constant for extra lysis
$\beta_p$	p_pu_ea	-	Excreted fraction of primary production
$\gamma_p$	p_pu_ra	-	Activity respiration fraction
	p_switchDOC	1-3	Switch for the type of DOC excretion. Choice consistent with bacteria parameterization in Sec. 2.3. 1. All DOC is released as $R_c^{(1)}$ (BACT1); 2. Activity DOC is released as $R_c^{(2)}$ (BACT2); 3. All DOC is released as $R_c^{(2)}$ (BACT3)
	p_netgrowth	logical	Switch for parameterization of nutrient limited growth (T or F)
	p_limnut	0-2	Switch for parameterization of nutrient co-limitation
$a_4$	p_qun	$m^3\ mg\ C^{-1}\ d^{-1}$	Specific affinity constant for N
$h_p^n$	p_lN4	mmol N-NH4 $m^{-3}$	Half saturation constant for ammonium uptake preference over ammonium
$n_p^{min}, n_p^{opt}, n_p^{max}$	p_qnlc, p_qncPPY, p_xqn*p_qncPPY	mmolN $mgC^{-1}$	Minimum, optimal and maximum nitrogen quota
$a_1$	p_qup	$m^3\ mg\ C^{-1}\ d^{-1}$	Specific affinity constant for P
$p_p^{min}, p_p^{opt}, p_p^{max}$	p_qplc, p_qpcPPY, p_xqp*p_qpcPPY	mmolP $mgC^{-1}$	Minimum, optimal and maximum phosphorus quota
	p_switchSi	1,2	Switch for parameterization of silicate limitation (1=external, 2=internal)
$h_p^s$	p_chPs	mmol Si $m^{-3}$	Half saturation constant for Si-limitation
$\rho_p^s$	p_Contois	-	Variable half saturation constant for Si-limitation of Contois (like Monod if 0)
$a_5$	p_qus	$m^3\ mg\ C^{-1}\ d^{-1}$	Specific affinity constant for Si
$s_p^{min}, s_p^{opt}$	p_qslc, p_qscPPY	mmolSi $mg\ C^{-1}$	Minimum and optimal Si:C ratio in silicifiers
$\omega_p^{sink}$	p_res	$m\ d^{-1}$	Maximum sedimentation rate
$l_p^{sink}$	p_esNI	-	Nutrient stress threshold for sinking
	p_switchChl		Choice of the Chl synthesis parameterization
$d_p^{chl}$	p_sdchl	$d^{-1}$	Chlorophyll turn-over rate
$\alpha_{chl}^0$	p_alpha_chl	$mgC\ (mg\ chl)^{-1}$ $\mu E^{-1}\ m^2$	Maximum light utilization coefficient
$\theta_{chl}^0$	p_qlcPPY	$mg\ chl\ mg\ C^{-1}$	Maximum chl:C quotient
$c_p$	p_epsChla	$m^2\ (mg\ chl)^{-1}$	Chl-specific light absorption coefficient
$\epsilon^{opt}$	p_EpEk_or	-	Optimal value of $E_{PAR}/E_K$
$\tau^{opt}$	p_tochl_relt	$d^{-1}$	Relaxation rate toward the optimal Chl:C value
	p_iswLtyp	0-6	Shape of the productivity function (diagnostic Chl, ChlDynamicsFlag=1)
$E_p^{max}, E_p^{min}$	p_chELiPPY p_clELiPPY	$W\ m^{-2}$	Maximum and minimum thresholds for light adaptation
$v_p^l$	p_ruELiPPY	$d^{-1}$	Relaxation rate toward the optimal light
	p_rPIm	$m\ d^{-1}$	Additional background sinking rate

Table 2.2.: Mathematical and code symbols, units and description of the phytoplankton parameters (namelist Pelagic\_Ecology.nml: Phyto\_parameters).

## 2. The pelagic plankton model

This equation ensures that the carbon and nutrients in the supportive structures, which are assumed to have  $p_p^{min}$  and  $n_p^{min}$  nutrient ratios, are always released as particulate components.

The model also implements an extra lysis rate in the last term of eq. (2.2.9-2.2.10), which is dependent on the population density. This term is controlled by an optional specific lysis rate

$$\chi^{lys} = d_p^x \frac{P_c}{P_c + h_p^x} P_c \quad (2.2.12)$$

which is usually included for those phytoplankton population that are inedible and therefore acts as an additional mortality term to regulate the population dynamics.

### 2.2.2. Multiple nutrient limitation

The BFM inherits the treatment of nutrient limitation from the original work by Baretta-Bekker et al. (1997) which has similarities to the Caperon and Meyer equation, with some specific extensions. Nutrients are divided in two main groups, the ones that directly control carbon photosynthesis (as silicate, since duplication can only occur with Si deposition) and the ones that are decoupled from carbon uptake because of the existence of cellular storage capabilities. Limiting factors for nutrients can be both internal (i.e. based on the internal nutrient quota) or external (based on dissolved inorganic concentration). The internal limitation is only partly based on Droop (1973), with the concepts of nutrient surge and storage by Baretta-Bekker et al. (1997) and the possibility to apply the parameterization of net growth described in Vichi et al. (2004) by means of the parameter `p_netgrowth` in the namelist (Tab. 2.2). The regulating factors for internal limitation are controlled by the optimal and minimum values for the existence of structural components ( $n_p^{opt}, n_p^{min}$ ), and they are implemented for N, P and Fe (Sec. 2.2.8) and also for Si (Lazzari et al., 2012), although in this case it is not possible to have luxury uptake because there is no storage for dissolved silicate in the cell:

$$f_p^n = \min \left( 1, \max \left( 0, \frac{P_n/P_c - n_p^{min}}{n_p^{opt} - n_p^{min}} \right) \right) \quad (2.2.13)$$

$$f_p^p = \min \left( 1, \max \left( 0, \frac{P_p/P_c - p_p^{min}}{p_p^{opt} - p_p^{min}} \right) \right) \quad (2.2.14)$$

$$f_p^f = \frac{P_f/P_c - \phi_p^{min}}{\phi_p^{opt} - \phi_p^{min}} \quad (2.2.15)$$

$$\hat{f}_p^s = \frac{P_s/P_c - s_p^{min}}{s_p^{opt} - s_p^{min}} \quad (2.2.16)$$

$$f_p^p = \min \left( 1, \max \left( 0, \frac{P_p/P_c - p_p^{min}}{p_p^{opt} - p_p^{min}} \right) \right) \quad (2.2.17)$$

Note that the ratios between brackets can be larger than 1 because the nutrient quota are allowed to reach the maximum values (cf. Sec. 2.2.3) but the regulating factor has to be limited to 1 because above the optimal quatum there is no limitation to physiological processes.

There is a flag (Tab. 2.2) for the choice of external and internal silicon limitation in case of diatoms. External dissolved silicate control should be preferable (Flynn, 2003) and it implements a Monod regulation with variable half-saturation constant  $h_p^s$ , modified according to Contois (1959):

$$f_{P^{(1)}}^s = \frac{N^{(5)}}{N^{(5)} + (h_p^s + \rho_p^s P_s^{(1)})} \quad (2.2.18)$$

$$f_{P^{(j)}}^s = 1, \quad j \neq 1$$

The Contois formulation implements a control on dissolved nutrient uptake that is dependent on the size of the population, in this case it is applied to biogenic silica as suggested by Tsiraras et al. (2008). If the Contois parameter is zero a classical Monod function is obtained, while if  $\rho_p^s \neq 0$  the half-saturation constant is increased and the resulting silicate control factor is smaller.

Multiple nutrient limitation is different for nutrients that can be stored in the cell and nutrients that cannot. The threshold combination (Liebig-like) is usually preferred to the multiplicative approach (Flynn, 2003): the BFM allows the three



alternative ways implemented in ERSEM-II to combine N and P limitation (that can be selected differently for each phytoplankton group, Tab. 2.2),

$$f_p^{n,p} = \min(f_p^n, f_p^p) \quad (2.2.19)$$

$$f_p^{n,p} = \frac{2}{1/f_p^n + 1/f_p^p} \quad (2.2.20)$$

$$f_p^{n,p} = \sqrt{f_p^n f_p^p} \quad (2.2.21)$$

and a simple multiplicative approach for the effect of nutrients that directly control photosynthesis (eq. 2.2.6), such as  $f^{PP} = \hat{f}_p^s$  as done by Lazzari et al. (2012) or  $f^{PP} = f_p^f f_p^s$  when iron dynamics is included (Sec. 2.3) as in Vichi et al. (2007b). The co-limitation from all nutrients is always done with a threshold method

$$f_p^{nut} = \min(f_p^{n,p}, f_p^f, f_p^s) \quad (2.2.22)$$

and it is considered in the parameterization of some processes such as chlorophyll synthesis and sinking (Secs. 2.2.6 and 2.2.9).

### 2.2.3. Nutrient uptake

A major problem in modelling nutrient uptake is to deal with unbalanced growth conditions, and any realistic application is expected to produce transient environmental conditions resulting in uncoupled assimilation rates of carbon and nutrients. The Droop (intracellular quota approach) and Monod (external concentration approach) equations produce consistent results when applied in balanced growth conditions (Morel, 1987). The BFM approach, largely derived from Baretta-Bekker et al. (1997), combines both mechanisms with a threshold control.

#### 2.2.3.1. Nitrogen

The uptake of DIN is the sum of the uptake of dissolved nitrate and ammonium and is the minimum between a diffusion-dependent uptake rate (when internal nutrient quota are low and nutrients are

only structural), and a rate based on considerations of balanced growth and luxury uptake:

$$\sum_{j=3,4} \frac{dP_n}{dt} \Big|_{N^{(j)}}^{upt} = \min \left( \left( a_p^n \frac{h_p^n}{h_p^n + N^{(4)}} N^{(3)} + a_p^n N^{(4)} \right) P_c, n_p^{opt} G_P + v_P \left( n_p^{\max} - \frac{P_n}{P_c} \right) P_c \right) \quad (2.2.23)$$

A preference for ammonium is parameterized through a saturation function that modulates the affinity constant for dissolved nitrate. Balanced uptake is a function of the net primary production  $G_P$ , which is computed as:

$$G_P = \max \left( 0, \frac{dP_c}{dt} \Big|_{O^{(3)}}^{gpp} - \frac{dP_c}{dt} \Big|_{R_c^{(i)}}^{exu} - \frac{dP_c}{dt} \Big|_{O^{(3)}}^{rsp} - \frac{dP_c}{dt} \Big|_{R_c^{(i)}}^{lys} \right) \quad (2.2.24)$$

and

$$v_P = \max \left( 0.05, \frac{G_P}{P_c} \right).$$

When the nitrogen uptake rate in eq. (2.2.23) is positive, the partitioning between  $N^{(3)}$  and  $N^{(4)}$  uptake is done by multiplying the rate by the fractions:

$$\varepsilon_P^{(3)} = \frac{a_p^n \frac{h_p^n}{h_p^n + N^{(4)}} N^{(3)}}{a_p^n N^{(4)} + a_p^n \frac{h_p^n}{h_p^n + N^{(4)}} N^{(3)}} \quad (2.2.25)$$

$$\varepsilon_P^{(4)} = \frac{a_p^n N^{(4)}}{a_p^n N^{(4)} + a_p^n \frac{h_p^n}{h_p^n + N^{(4)}} N^{(3)}} \quad (2.2.26)$$

When it is negative, the whole flux is directed to the DON pool  $R_n^{(1)}$ .

#### 2.2.3.2. Phosphorus

Phosphate uptake is simpler than N uptake as one single species is considered:

$$\frac{dP_p}{dt} \Big|_{N^{(1)}}^{upt} = \min \left( a_p^{(1)} N^{(1)} P_c, p_p^{opt} G_P + v_P \left( p_p^{\max} - \frac{P_p}{P_c} \right) P_c \right) \quad (2.2.27)$$

## 2. The pelagic plankton model

### 2.2.3.3. Silicate

Silicate is not stored in the cell and therefore the uptake is directly proportional to the net carbon growth (see eq. 2.2.24):

$$\left. \frac{dP_s}{dt} \right|_{N^{(5)}}^{upt} = s_P^{opt} G_P \quad (2.2.28)$$

### 2.2.4. Nutrient loss associated with lysis

Nutrients in the cell are not evenly distributed between cytoplasm and structural parts. When the cell wall is disrupted, part of the nutrients are released as dissolved organic matter (the nutrients in the cytoplasm) and part as particulate organic matter (the nutrients in the structural parts, such as the cell wall).

The redistribution of the cellular elements C, N and P over the excretion variables reflects the preferential remineralization of P and to a lesser extent of N, with respect to C. This parameter values are based on the ERSEM-II parameterizations (Baretta-Bekker et al., 1997).

$$\left. \frac{dP_p}{dt} \right|_{R_i^{(6)}}^{lys} = \varepsilon_p^i \frac{h_p^{p,n}}{f_p^{p,n} + h_p^{p,n}} d_p^0 P_i \quad i = n, p \quad (2.2.29)$$

$$\left. \frac{dP_p}{dt} \right|_{R_i^{(1)}}^{lys} = (1 - \varepsilon_p^i) \frac{h_p^{p,n}}{f_p^{p,n} + h_p^{p,n}} d_p^0 P_i \quad i = n, p \quad (2.2.30)$$

In the case of Si, the release is always in particulate form and thus is a constant fraction of the particulate carbon lysis

$$\left. \frac{dP_s^{(1)}}{dt} \right|_{R_s^{(6)}}^{lys} = s_P^{opt} \left. \frac{dP_c^{(1)}}{dt} \right|_{R_c^{(6)}}^{lys} \quad (2.2.31)$$

### 2.2.5. Exudation of carbohydrates

In the case of intra-cellular nutrient shortage, not all photosynthesized carbon can be assimilated into biomass, and the non-assimilated part is released in the form of dissolved carbohydrates. The model considers three different types

of DOC (Tab. 1.1) and phytoplankton excretion must be consistent with the bacteria parameterization (Sec. 2.3). Carbohydrates are excreted when phytoplankton cannot equilibrate the fixed C with sufficient nutrients to maintain the minimum quatum needed for the synthesis of new biomass. The choice of the parametrization for DOC exudation is controlled by the flag parameters `p_netgrowth` and `p_switchDOC` in the phytoplankton namelist (Tab. 2.2), which can be set differently for each sub-group. There is a runtime check that controls the consistency between the two parameters. When the flag is false, the ERSEM-II parameterization (Baretta-Bekker et al., 1997) as implemented in Vichi et al. (2007b) is used,

$$\left. \frac{dP_c}{dt} \right|_{R_c^{(1)}}^{exu} = [\beta_p + (1 - \beta_p)(1 - f_p^{n,p})] \left. \frac{dP_c}{dt} \right|_{O^{(3)}}^{gpp} \quad (2.2.32)$$

where exudation (and thus carbon biomass loss) increases when phytoplankton has low nutrient:carbon ratios. The nutrient-stress excretion can also be partly directed to semi-refractory DOC ( $R_c^{(2)}$ ) by setting the parameter `p_switchDOC=3`:

$$\left. \frac{dP_c}{dt} \right|_{R_c^{(1)}}^{exu} = \beta_p \left. \frac{dP_c}{dt} \right|_{O^{(3)}}^{gpp} \quad (2.2.33)$$

$$\left. \frac{dP_c}{dt} \right|_{R_c^{(2)}}^{exu} = (1 - \beta_p)(1 - f_p^{n,p}) \left. \frac{dP_c}{dt} \right|_{O^{(3)}}^{gpp} \quad (2.2.34)$$

However, the ERSEM-II parameterization not only leads to the desired extra release of C-enriched DOM but also to a decrease of the population biomass. It has been shown by Vichi et al. (2004) that the use of a different parameterization results in the maintenance of higher standing stocks in the post bloom period with a consequently enhanced consumption of the non-limiting nutrients. This parameterization is also used by Lazzari et al. (2012) to allow the consumption of N species in a P-depleted environment.

When the `p_netgrowth` flag is true, total exudation is directed to the state variable  $R_c^{(2)}$  (see

also Sec. 2.3 for a detailed explanation of DOM in the BFM), and it is written as the sum of an activity exudation linked to the gross primary production and a balance term

$$\frac{dP_c}{dt} \Big|_{R_c^{(2)}}^{exu} = \beta_P \frac{dP_c}{dt} \Big|_{O^{(3)}}^{gpp} + G_P - G_P^{bal} \quad (2.2.35)$$

where

$$G_P^{bal} = \max \left( 0, \min \left( G_P, \frac{1}{n_P^{min}} \sum_{j=3,4} \frac{dP_n}{dt} \Big|_{N^{(j)}}^{upt}, \frac{1}{p_P^{min}} \frac{dP_p}{dt} \Big|_{N^{(1)}}^{upt} \right) \right) \quad (2.2.36)$$

### 2.2.6. Chlorophyll synthesis and photoacclimation

The chlorophyll equation in (2.2.1d) is composed of two terms. The first one is net chlorophyll synthesis, which is mostly derived from Geider et al. (1996, 1997) with some adaptations, and the second one represents the losses due to grazing.

Net chlorophyll synthesis is namely a function of acclimation to light conditions, nutrient availability and turnover rate. The former process is taken into account by Geider's parameterization, while the latter is generally parameterized with different formulations, for instance by assuming a dependence on gross carbon uptake (Geider et al., 1997; Blackford et al., 2004) and/or on nitrogen assimilation (Geider et al., 1998; Flynn et al., 2001). To integrate the variety of processes into our formulations, we consider three different parameterizations presented in 2.2 that have been used in different applications of the BFM (Vichi and Masina (2009), Lazzari et al. (2012), Clementi et al., in preparation). The synthesis part is rather similar as it is controlled by the dynamical chl:C ratio  $\rho_{chl}$  proposed by Geider et al. (1997), which regulates the amount of chlorophyll in the cell according to a non-dimensional ratio between the realized photosynthetic rate in eq. (2.2.6) and the maximum potential photosyn-

thesis:

$$\rho_{chl} = \theta_{chl}^0 \frac{\frac{dP_c}{dt} \Big|_{O^{(3)}}^{gpp}}{\alpha^* E_{PAR} P_l} \quad (2.2.38)$$

and multiplying by a maximum chl:C ratio  $\theta_{chl}^0$  which is different for each phytoplankton functional group (Tab. 2.2). The major difference in eq. (2.2.37b) proposed by Lazzari et al. (2012) is the presence of the combined nutrient regulating factor, which implies that chl synthesis is reduced in regions limited by phosphorus like for instance the Mediterranean.

Following the notation shown in Sec. 2.2.3, Geider's original formulation is rewritten after some algebra as:

$$\rho_{chl} = \theta_{chl}^0 \frac{f_P^E r_P^0 P_c}{\alpha_{chl}^0 E_{PAR} P_l} \quad (2.2.39)$$

The ratio is down-regulated when the rate of light absorption (governed by the quantum efficiency and the amount of light-harvesting pigments) exceeds the rate of utilization of photons for carbon fixation, as explained in detail in Geider et al. (1996). Also here it is assumed that both  $\alpha^*$  and  $P_m^*$  are controlled by the same regulating factors (Jassby and Platt, 1976; Behrenfeld et al., 2004).

The formulation of the lysis term is still unknown and this is reflected in the diversity of parameterizations that are available in the model and controlled by the namelist parameter `p_switchChl` (Tab. 2.2). The user should consider the different assumptions and use them accordingly. A different parameterization can be used for each phytoplankton group to allow their testing. In eq. (2.2.37a) it is assumed that chl lysis is simply linked to the carbon term, while in eq. (2.2.37b) there is a relaxation to the optimal chl:C ratio with an additional lysis term linked to background mortality. The parameterization proposed in eq. (2.2.37c) is slightly more elaborated as it considers an optimal cell acclimation to light that corresponds to an optimal value  $E_{PAR}/E_K = \varepsilon^{opt}$  of the exponential in eq. (2.2.4).

The theoretical chlorophyll concentration corresponding to optimal light acclimation in eq. (2.2.37c) is computed as follows:

## 2. The pelagic plankton model

**Equation Box 2.2** Different parameterizations for the chlorophyll synthesis.

$$\left. \frac{dP_l}{dt} \right|^{syn} = \rho_{chl} G_P - \frac{P_l}{P_c} \left. \frac{dP_c}{dt} \right|^{lys} \quad (2.2.37a)$$

$$\left. \frac{dP_l}{dt} \right|^{syn} = f_P^{p,n} \rho_{chl} G_P - \max(0, d_P^s (1 - f_P^{p,n})) P_l - \min(0, G_P) * \max(0, P_l - \theta_{chl}^0 P_c) \quad (2.2.37b)$$

$$\left. \frac{dP_l}{dt} \right|^{syn} = \rho_{chl} G_P - \theta_{chl} \left( \left. \frac{dP_c}{dt} \right|^{lys} + \left. \frac{dP_c}{dt} \right|^{rsp} \right) - \max(0, P_l - P_l^{opt}) \tau_{chl} \quad (2.2.37c)$$

$$\left. \frac{dP_l}{dt} \right|^{syn} = \rho_{chl} G_P - d_P^{chl} P_l (h_P^{p,n,s} - f_P^{nut}) - \frac{P_l}{P_c} \frac{1}{1 + E_{PAR}} \left. \frac{dP_c}{dt} \right|^{rsp} \quad (2.2.37d)$$

$$\begin{aligned} \frac{r_P^0 P_c}{P_l^{opt} \alpha_{chl}^0} &= \frac{E_{PAR}}{\varepsilon^{opt}} \\ P_l^{opt} &= \varepsilon^{opt} \frac{r_P^0 P_c}{\alpha_{chl}^0 E_{PAR}} \end{aligned} \quad (2.2.40)$$

and the chl content in (2.2.37c) is relaxed to this optimal value with a specific time scale parameter  $\tau_{chl}$ .

The parameterization presented in eq. (2.2.37d) has instead an explicit term for the turn-over rate of chl,  $d_P^{chl}$ . The losses of chlorophyll are not considered as mass losses in the model because we have currently not implemented a chl component in detritus and dissolved organic matter. The same consideration applies to the ingested chl fraction in zooplankton. All these terms are presently collected into a generic sink term used for mass conservation purposes, which can be easily split into its major components once it is deemed necessary to follow the degradation products of chl (phaeopigments).

### 2.2.7. Light limitation and photoacclimation based on optimal light

This parameterization is alternative to the one above and is consistent with the one originally implemented in ERSEM-II (Ebenhöh et al., 1997). It assumes that phytoplankton is acclimated to the prevailing light in a few days and that the C:chl ratio is constant.

The state variable  $I_{opt}$  in the original ERSEM-II formulation represented the light intensity at which production saturated for the whole phytoplankton community. We consider here an optimal light for each phytoplankton group indicated with  $\hat{P}_l^{(j)}$ , which has the same meaning as the light saturation parameter  $E_k$  used in the alternative formulation of chlorophyll dynamics (Sec. 2.2.3).

A note of caution on the application of this parameterization: the model was formulated to simulate the daily production, therefore it is suggested to apply it with the daylight-averaged irradiance, possibly modulated by the duration of the daylight period (see Sec. 2.1). Several forms of the P-E curve are available:

$$prod = f_P^T f_P^s r_{0P} \min \left( 1, \frac{E_{PAR}}{\hat{P}_l} \right) \quad (\text{ramp})$$

$$prod = f_P^T f_P^s r_{0P} \frac{E_{PAR}}{\hat{P}_l} e^{1 - \frac{E_{PAR}}{\hat{P}_l}} \quad (\text{Steele})$$

The light regulating factor is computed by integrating the P-E curve over the depth of the considered layer, therefore the irradiance at the top of the layer is used

$$f_P^E = \frac{1}{f_P^T f_P^s r_{0P} D} \int_{-D}^0 prod \left( \frac{E_{PAR}}{\hat{P}_l} \right) dz \quad (2.2.41)$$

The time rate of change of  $\hat{P}_l$  is computed with a relaxation term

$$\left. \frac{d\hat{P}_l}{dt} \right|_{bio} = v_p^I (E_p^{opt} - \hat{P}_l) \quad (2.2.42)$$

where  $E_p^{opt}$  is the reference light saturation parameter to which the phytoplankton adapt with frequency  $v_p^I$  (generally 4 days for a full acclimation).

The irradiance level to which phytoplankton may adapt is

$$E_p^{opt} = \min(E_p^{max}, \max(E_p^{min}, E_{PAR}))$$

which is a constrained ramp function over the range of saturating irradiance.

### 2.2.8. Iron in phytoplankton

The iron (Fe) constituent in phytoplankton shown in eq. (2.2.1f) is not activated by default in the model. It is available as a compilation key `INCLUDE_PELFE` and implements the iron dynamics proposed by Vichi et al. (2007b) described by the parameters of Tab. 2.3. The iron cycle involves phytoplankton, particulate and dissolved component (Sec. ), while the zooplankton and bacteria fraction is neglected.

The equation (2.2.1f) for iron in phytoplankton  $P_f$  contains a term for the uptake of Fe, a loss term related to turnover/cell lysis and a predation term. Similarly to N and P content, intracellular Fe:C quota are allowed to vary between a maximum and a minimum thresholds ( $\phi_p^{max}$  and  $\phi_p^{min}$ , Tab. 2.3), and the realized quotient is used to derive a non-dimensional regulating factor as in eq. (2.2.19). The allowed minimum ratio  $\phi_p^{min}$  represents the evolutive adaptation of each functional group at the prevailing iron concentrations, and the optimal value  $\phi_p^{opt}$  indicates the cellular requirement for optimal growth. This regulating factor modulates the actual photosynthetic rate in eq. (2.2.6), since there is a clear decrease in the activity of PSUs due to insufficient cellular Fe (Sunda and Huntsman, 1997).

The regulating factor inhibits carbon fixation, but iron can still be taken up in the cell, progressively increasing the internal quotient. Iron uptake

from dissolved pools is computed as for N and P (Sec. 2.2.3) by taking the minimum of two rates, a linear function of the ambient concentration simulating the membrane through-flow at low external Fe concentration, and the balancing flux according to the carbon assimilation:

$$\left. \frac{\partial P_f}{\partial t} \right|_{N^{(7)}}^{upt} = \min \left( a_p^7 N^{(7)} P_c, \phi_p^{opt} G_{P+} \right) \quad (2.2.43)$$

$$+ f_p^T r_p^0 \left( \phi_p^{max} - \frac{P_f}{P_c} \right) P_c$$

It is assumed that the only physiological iron loss from phytoplankton is linked to cell disruption, computed according to carbon lysis and assuming that particulate material has the minimum structural Fe:C ratio:

$$\left. \frac{\partial P_f}{\partial t} \right|_{R_f^{(6)}}^{lys} = \phi_p^{min} \left. \frac{\partial P_c}{\partial t} \right|_{R_c^{(6)}}^{lys} \quad (2.2.44)$$

### 2.2.9. Phytoplankton sinking

The sinking of biogenic material is a fundamental process for the simulation of carbon sequestration in the interior of the ocean. However, the estimation of the sinking velocity  $w_B$  is still parameterized in a very simplified way in the model. Any phytoplankton group is allowed to have a sinking velocity using the original ERSEM formulation (Varela et al., 1995). This is generally valid only for diatoms, which reach their maximum velocity  $\omega^{sink}$  as a function of the total nutrient stress (2.2.22) as follows:

$$w_{p(1)} = \omega^{sink} \max \left( 0, l^{sink} - f_p^{nut} \right) \quad (2.2.45)$$

where  $l^{sink}$  is the nutrient regulating factor value below which the mechanism is effective.

## 2.3. Bacterioplankton

Bacterioplankton is included in the standard BFM with one single state variable representing a wide

## 2. The pelagic plankton model

<i>Symbol</i>	Code	Unit	Description
$a_7$	p_quf	$\text{m}^{-3} \text{mg C}^{-1} \text{d}^{-1}$	Specific affinity constant for Fe in phytoplankton
$\phi_p^{min}, \phi_p^{opt}, \phi_p^{max}$	p_qflc, p_qfcPPY, p_xqf*p_qfcPPY	$\mu\text{mol Fe mgC}^{-1}$	Minimum, optimal and maximum iron quota in phytoplankton
$\Lambda_1^{f^{min}}$	p_sR1N7	$\text{d}^{-1}$	Specific remineralization rate of dissolved biogenic iron
$\Lambda_6^{f^{min}}$	p_sR6N7	$\text{d}^{-1}$	Specific remineralization rate of particulate biogenic iron
$Q_{10_f}$	p_q10R6N7	(-)	Characteristic Q10 coefficient for Fe remineralization
$\phi_f^{scv}$	p_N7fsol	$\mu\text{mol Fe m}^{-3}$	Solubility concentration
$\Lambda_f^{scv}$	p_scavN7f	$\text{d}^{-1}$	Specific scavenging rate of dissolved iron
$\Lambda_f^{dep}$	p_qflc	(-)	Specific dissolution fraction of dust iron

Table 2.3.: Mathematical and code symbols, units and description of the iron cycle parameters (namelist `Pelagic_Ecology.nml:Phyto_parameters_iron` `Pelagic_environment.nml:PelChem_parameters_iron`).

group of aerobic and anaerobic bacteria. The user can eventually expand the number of bacteria group using the modular facilities described in Part II of this document and by providing new dynamical equations in the code. The main source of carbon for bacterioplankton is the organic matter pool that is composed of particulate detritus (variables  $R^{(6)}$ ) and dissolved organic matter (DOM, variables  $R^{(1)}$  and  $R^{(2)}$ ).

In addition to the original ERSEM parameterization (Baretta-Bekker et al., 1995) further expanded in Vichi et al. (2007b), the code contains also two alternative parameterizations proposed by Vichi et al. (2004) and Polimene et al. (2006). We will refer to BACT1 when indicating the standard most simple parameterization and to BACT2 and BACT3 for the Vichi et al. (2004) and Polimene et al. (2006) parameterizations, respectively. BACT1 set of equations is the default choice but all parameterizations are deemed equal and can be activated at run time.

The different parameterizations consider that dissolved organic matter (DOM) available to pelagic bacteria may have different degrees of lability/refractivity (see Tab. 1.1). The lability/refractivity characteristics of DOM are dependent

on two factors: the C:N and C:P ratios of bacteria and the structure of organic molecules constituting the DOM matrix. DOM is assumed to be partitioned into three broad and distinct state variables, each of them corresponding to different degrees of lability/refractivity and having different production pathways. The parameterizations described below consider only one, two or all of the 3 classes. It is important to remark that the DOC fraction considered by the model covers only the labile and the semi-labile DOC part. Therefore, in the following we define, as “semi-refractory” the DOC fraction more slowly remineralized by bacteria only to avoid confusion with the truly refractory DOC (with turnover time of 100-1000 years) that is not considered at all in the model.

The most labile fraction of the total DOM pool  $R_i^{(1)}$ ,  $i = c, n, p$  is produced by phytoplankton, zooplankton and bacteria via the lysis, mortality and sloppy feeding (mesozooplankton only) processes. This DOM variable is characterized by C:N and C:P ratios identical to those of the producing functional groups. The characteristic turnover time-scale is assumed to be 1 day. The semi-labile DOM fraction  $R_c^{(2)}$  is produced through excretion by phytoplankton and

bacteria in order to achieve/maintain their internal “optimal” stoichiometry (this part is considered only in BACT2 and BACT3 parameterizations). The production process of semi-labile DOM can be thought as release of excess carbon and, therefore, negligible N and P pools are assumed. The characteristic turnover time-scale is assumed to be 10 days. DOM released by bacteria as capsular material  $R_c^{(3)}$  is also introduced in BACT2 and BACT3, and it represents the semi-refractory fraction of the DOM, but it is only considered as a source of carbon in BACT3 (Polimene et al., 2006). This component of the DOM pool is also assumed (as for the semi-labile fraction) to be DOC only and to be formed by high molecular weight substances such as polysaccharid fibrils (Heissenberger et al., 1996), which are quite resistant to enzymatic attack (Stoderegger and Herndl, 1998). Therefore, the characteristic turnover time-scale is assumed to be longer (100 days), as this material is only degradable by bacteria at time-scales of 2-3 orders of magnitude longer with respect to the labile DOC (Stoderegger and Herndl, 1998).

Bacteria have 3 free-varying constituents C, N, P, and the fundamental equations shown in Eq. Box 2.3 are common to all parameterizations. In all versions, pelagic bacteria behave as remineralizers or phytoplankton competitors depending on their internal nutrient quota, taking up inorganic nutrients directly from the water. Before providing a detailed description of the three versions the common processes are described.

### 2.3.1. Regulating factors

The oxygen non dimensional regulating factor  $f_B^o$  (eq. 2.3.2) is parameterized with a type III control formulation as:

$$f_B^o = \frac{(O^{(2)})^3}{(O^{(2)})^3 + (h_B^o)^3} \quad (2.3.2)$$

where the dissolved oxygen concentration  $O^{(2)}$  is considered, and  $h_B^o$  is the oxygen concentration at which metabolic functionalities are halved. This steep sigmoid has been proposed by Vichi et al. (2004) to efficiently switch between bacteria

metabolism under aerobic conditions and anaerobic metabolism.

The non dimensional regulating factor based on the nutritional content of bacterial cells is given by:

$$f_B^{n,p} = \min \left( 1, \frac{B_p/B_c}{p^{opt}}, \frac{B_n/B_c}{n^{opt}} \right); \quad (2.3.3)$$

$n_B^{opt}$  and  $p_B^{opt}$  are the “optimal”  $N : C$  and  $P : C$  bacterial internal quota (Goldman and McCarthy, 1978).

### 2.3.2. Respiration

The respiration sink term is composed of basal and activity respiration as:

$$\frac{dB_c}{dt} \Big|_{O^{(3)}}^{rsp} = b_B f_B^T B_c + [\gamma_B^a + \gamma_B^o (1 - f_B^o)] \sum_{j=1,2,6} \frac{dB_c}{dt} \Big|_{R_c^{(j)}}^{upr} \quad (2.3.4)$$

The basal respiration is parameterized as for phytoplankton with a constant specific respiration rate  $b_B$  and the regulating factor for temperature given in eq. (2.1.1).  $\gamma_B^a$  and  $\gamma_B^o$  are the fraction of production that is used for activity respiration under oxic and low oxygen conditions respectively. Since the BFM pelagic bacteria parameterization encompasses both aerobic and anaerobic bacterial activities, we consider here the differences in the energetics of the metabolic pathways in relation to oxygen availability. Anaerobic bacteria have a lower efficiency because they need to consume (respire) more carbon in order to produce the same amount of energy.

### 2.3.3. Mortality

The mortality (lysis) process is given by

$$\frac{dB_c}{dt} \Big|_{R_i^{(1)}}^{lys} = (d_{0B} f_B^T + d_B^d B_c) B_c \quad i = c, n, p \quad (2.3.5)$$

## 2. The pelagic plankton model

<i>Symbol</i>	<i>Code</i>	<i>Units</i>	<i>Description</i>	<i>Parameterization</i>
$Q_{10B}$	p_q10	(-)	Characteristic Q10 coefficient	All
$h_B^o$	p_chdo	mmolO <sub>2</sub> m <sup>-3</sup>	Half saturation value for oxygen limitation	All
$r_{0B}$	p_sum	d <sup>-1</sup>	Potential specific growth rate	All
$b_B$	p_srs	d <sup>-1</sup>	Basal specific respiration rate	All
$\gamma_B^a$	p_pu_ra	(-)	Activity respiration fraction	All
$\gamma_B^o$	p_pu_ra_o	(-)	Additional respiration fraction under anoxic conditions	All
$d_{0B}$	p_sd	d <sup>-1</sup>	Specific mortality rate	All
$d_B^d$	p_sd2	d <sup>-1</sup> mgC <sup>-1</sup> m <sup>3</sup>	Density-dependent specific mortality rate	All
$V_B^{R^{(2)}}$	p_suR2	d <sup>-1</sup>	Specific potential $R^{(2)}$ uptake (semi-labile)	BACT2,BACT3
$V_B^{R^{(3)}}$	p_suR3	d <sup>-1</sup>	Specific potential $R^{(3)}$ uptake (semi-refractory)	BACT3
$V_B^{R^{(6)}}$	p_suR6	d <sup>-1</sup>	Specific potential $R^{(6)}$ uptake (particulate)	All
$V_B^{R^{(1)}}$	p_suhR1	d <sup>-1</sup>	Specific quality-dependent potential $R^{(1)}$ uptake (nutrient-rich labile)	All
$V_{0B}^{R^{(1)}}$	p_sulR1	d <sup>-1</sup>	Specific quality-independent potential $R^{(1)}$ uptake (nutrient-poor labile)	BACT1
$a_{1B}$	p_qup	m <sup>-3</sup> mg C <sup>-1</sup> d <sup>-1</sup>	Specific affinity constant for P	BACT2
$a_{4B}$	p_qun	m <sup>-3</sup> mg C <sup>-1</sup> d <sup>-1</sup>	Specific affinity constant for N	BACT2
$v_B^n, v_B^p$	p_ruen, p_ruep	d <sup>-1</sup>	Relaxation time scales for N and P uptake or remineralization	All
$V_B^c$	p_rec	d <sup>-1</sup>	Relaxation time scale for semi-labile carbon release	BACT3
$n_B^{opt}, p_B^{opt}$	p_qncPBA p_qpcPBA	mmolN mgC <sup>-1</sup> , mmolP mgC <sup>-1</sup>	Optimal nutrient quota	All
$n_B^{min}, p_B^{min}$	p_qlnc, p_qlpc	mmolN mgC <sup>-1</sup> , mmolP mgC <sup>-1</sup>	Minimum nutrient quota	BACT2
$h_B^n, h_B^p$	p_chn, p_chp	mmolN mgC <sup>-1</sup> , mmolP mgC <sup>-1</sup>	Half saturation for nutrient uptake	All
$\beta_B$	p_pu_ea_R3	(-)	Fractional excretion of $R^{(3)}$ (semi-refractory)	BACT3
-	p_version		Switch for bacteria parameterization: 1=BACT1; 2=BACT2; 3=BACT3	

Table 2.4.: Mathematical and code symbols, units and description of the bacterioplankton parameters (namelist Pelagic\_Ecology.nml: PelBac\_parameters).



**Equation Box 2.3** Bacteria equations

$$\left. \frac{dB_c}{dt} \right|_{bio} = \sum_{j=1,6} \left. \frac{dB_c}{dt} \right|_{R_c^{(j)}}^{upt} - \left. \frac{dB_c}{dt} \right|_{O^{(3)}}^{rsp} - \left. \frac{dB_c}{dt} \right|_{R_c^{(1)}}^{lys} - \sum_{k=5,6} \left. \frac{dB_c}{dt} \right|_{Z_c^{(k)}}^{prd} \quad (2.3.1a)$$

$$\left. \frac{dB_n}{dt} \right|_{bio} = \sum_{j=1,6} \frac{R_n^{(j)}}{R_c^{(j)}} \left. \frac{dB_c}{dt} \right|_{R_c^{(j)}}^{upt} + \sum_{i=3,4} \left. \frac{dB_n}{dt} \right|_{N^{(i)}}^{upt} - \left. \frac{dB_n}{dt} \right|_{N^{(4)}}^{rel} - \frac{B_n}{B_c} \left. \frac{dB_c}{dt} \right|_{R_c^{(1)}}^{lys} + \quad (2.3.1b)$$

$$- \frac{B_n}{B_c} \sum_{k=5,6} \left. \frac{dB_c}{dt} \right|_{Z_c^{(k)}}^{prd} \quad (2.3.1c)$$

$$\left. \frac{dB_p}{dt} \right|_{bio} = \sum_{j=1,6} \frac{R_p^{(j)}}{R_c^{(j)}} \left. \frac{dB_c}{dt} \right|_{R_c^{(j)}}^{upt} + f_B^p \left. \frac{dB_p}{dt} \right|_{N^{(1)}}^{upt,rel} - \frac{B_p}{B_c} \left. \frac{dB_c}{dt} \right|_{R_c^{(1)}}^{lys} - \frac{B_p}{B_c} \sum_{k=5,6} \left. \frac{dB_c}{dt} \right|_{Z_c^{(k)}}^{prd} \quad (2.3.1d)$$

where  $d_{0_B}$  is a temperature enhanced background mortality specific rate and  $d_B^d$  is a density dependent mortality specific rate assumed to be dependent on virus infection.

**2.3.4. BACT1 parameterization**

In this parameterization labile DOC ( $R_{c,n,p}^{(1)}$ ) is the only class of dissolved organic matter resolved by the model and, together with Particulate Organic Detritus ( $R_{c,n,p}^{(6)}$ ), constitute the organic substrate available to bacteria.

**2.3.4.1. Substrate uptake**

The total carbon uptake rate of organic substrate in (2.3.1a) is regulated by environmental factors and substrate availability with a threshold formulation:

$$\sum_{j=1,6} \left. \frac{dB_c}{dt} \right|_{R_c^{(j)}}^{upt} = \min (f_B^{n,p} f_B^T r_{0_B} B_c, \quad (2.3.6)$$

$$\sum_{j=1,6} v_B^{R^{(j)}} f_{R^{(j)}}^{n,p} R_c^{(j)} + v_{0_B}^{R^{(1)}} (1 - f_{R^{(1)}}^{n,p}) R_c^{(1)})$$

where  $r_{0_B}$  is the maximum potential specific growth rate,  $v_B^{R^{(j)}}$  is the specific quality-dependent uptake rate for substrate,  $v_{0_B}^{R^{(1)}}$  is the specific, quality-independent uptake rate for semi-labile organic matter and  $f_{R^{(j)}}^{n,p}$  is the non-dimensional regulating factor based on the of organic substrate

$$f_{R^{(j)}}^{n,p} = \min \left( 1, \frac{R_p^{(j)}/R_c^{(j)}}{p^{opt}}, \frac{R_n^{(j)}/R_c^{(j)}}{n^{opt}} \right) \quad j = 1, 6, f_{R^{(j)}}^{n,p} \quad (2.3.7)$$

The uptake of the nutrient components in the dissolved and particulate fractions is then derived from the actual nutrient ratios in the organic matter as:

$$\left. \frac{dB_i}{dt} \right|_{R_i^{(j)}}^{upt} = \frac{R_i^{(j)}}{R_c^{(j)}} \left. \frac{dB_c}{dt} \right|_{R_c^{(j)}}^{upt}, \quad i = n, p; j = 1, 6 \quad (2.3.8)$$

**2.3.4.2. Nutrient release and uptake**

The mineralizers/phytoplankton competitors behavior is controlled by the non-dimensional factors  $f_B^p$  and  $f_B^n$  and by the specific relaxation rates  $v_B^p$  and  $v_B^n$  towards the optimal internal quota. The process it involves only phosphate and ammonium components:

$$\left. \frac{dB_p}{dt} \right|_{N^{(1)}}^{upt,rel} = f_B^p v_B^p \left\| \frac{B_p}{B_c} - p_B^{opt} \right\| B_c \quad (2.3.9)$$

$$\left. \frac{dB_n}{dt} \right|_{N^{(4)}}^{upt,rel} = f_B^n v_B^n \left\| \frac{B_n}{B_c} - n_B^{opt} \right\| B_c \quad (2.3.10)$$

$$\left. \frac{dB_n}{dt} \right|_{N^{(3)}}^{upt} = 0 \quad (2.3.11)$$

## 2. The pelagic plankton model

In the case of phosphorus as in eq. (2.3.9), for instance, if there is an excess of nutrients in the cell,  $\frac{B_p}{B_c} - p_B^{opt} > 0$ , the non-dimensional parameter  $f_B^p = -1$ , and if  $\frac{B_p}{B_c} - p_B^{opt} < 0$  there is direct uptake from the water as a function of the nutrient concentration in a Michaelis-Menten form,  $f_B^p = \frac{N^{(1)}}{N^{(1)} + h_B^p}$ . The same applies to nitrogen, and the direct uptake is regulated by the factor  $f_B^n = \frac{N^{(4)}}{N^{(4)} + h_B^n}$ .

Remineralization dynamics occur only when internal quotas are in excess with respect to the ‘‘optimal’’ value and the dissolved nutrient uptake is linearly dependent on the membrane affinity as follows:

$$\left. \frac{dB_p}{dt} \right|_{N^{(1)}}^{upt} = \min \left[ a_B^1 N^{(1)} B_c, \max \left( 0, p_B^{opt} G_B - \sum_{j=1,6} \left. \frac{dB_p}{dt} \right|_{R_p^{(j)}}^{upt} \right) \right] \quad (2.3.14)$$

### 2.3.4.3. Excretion

In this parameterization the release term appearing in eq. (2.3.1a) is nil.

$$\left. \frac{dB_p}{dt} \right|_{N^{(1)}}^{rel} = \max \left( 0, \sum_{j=1,6} \left. \frac{dB_p}{dt} \right|_{R_p^{(j)}}^{upt} - p_B^{opt} G_B \right) \quad (2.3.15)$$

### 2.3.5. BACT2 parameterization

In this parameterization originally proposed by Vichi et al. (2004), the substrate available for uptake is composed of  $R_{c,n,p}^{(1,6)}$  and  $R_c^{(2)}$ .

$$\left. \frac{dB_n}{dt} \right|_{N^{(4)}}^{rel} = \max \left( 0, \sum_{j=1,6} \left. \frac{dB_n}{dt} \right|_{R_n^{(j)}}^{upt} - n_B^{opt} G_B \right) \quad (2.3.16)$$

#### 2.3.5.1. Substrate uptake

The  $R_c^{(1,6)}$  uptake is parameterized as in BACT1 (see eq.2.3.6) and the  $R_c^{(2)}$  uptake is added.

$$\sum_{j=1,2,6} \left. \frac{dB_c}{dt} \right|_{R_c^{(j)}}^{upt} = \min \left( f_B^{n,p} f_B^T r_{0B} B_c, \sum_{i=3,4} \left. \frac{dB_n}{dt} \right|_{N^{(i)}}^{upt} \min \left( a_{4B} \frac{h_B^n}{h_B^n + N^{(4)}} N^{(3)} + a_{4B} N^{(4)} \right) B_n, \max \left( 0, n_B^{opt} G_B - \sum_{j=1,6} \left. \frac{dB_n}{dt} \right|_{R_n^{(j)}}^{upt} \right) \right) \quad (2.3.12)$$

$$\sum_{j=1,6} v_B^{R^{(j)}} f_B^{n,p} R_c^{(j)} + v_{0B}^{R^{(1)}} \left( 1 - f_B^{n,p} \right) R_c^{(1)} + v_B^{R^{(2)}} R_c^{(2)} \quad (2.3.17)$$

where  $v_B^{R^{(2)}}$  is the  $R_c^{(2)}$  specific uptake rate. The uptake of the nutrient components in the dissolved and particulate fractions is the same defined for BACT1 in eq. (2.3.8).

#### 2.3.5.2. Nutrient release and uptake

The uptake dynamics is similar to the one for phytoplankton, with affinity constants for phosphate and ammonia ( $a_{1B}$  and  $a_{4B}$  respectively) and also nitrate with a inhibition factor due to ammonium. This flux regulates the direct uptake and the activity uptake based on the optimal quota and the net carbon uptake

$$G_B = \sum_{j=1,2,6} \left. \frac{dB_c}{dt} \right|_{R_c^{(j)}}^{upt} - \left. \frac{dB_c}{dt} \right|_{O^{(3)}}^{rsp} \quad (2.3.13)$$

### 2.3.6. BACT3 parameterization

#### 2.3.6.1. Substrate uptake

The organic substrate uptake differs from the BACT1 and BACT2 parameterizations not only for the wider resolution of the DOM lability/refractivity characteristics given in the introduction, but also because the DOC uptake is not constrained by the nutritional content of bacterial cells (see eq. 2.3.3)

$$\sum_{j=1,2,3,6} \left. \frac{dB_c}{dt} \right|_{R_c^{(j)}}^{upt} = \min \left( f_B^T f_B^o r_{0B} B_c, \sum_{j=1,2,3,6} v_B^{R^{(j)}} R_c^{(j)} \right) \quad (2.3.18)$$

The uptake of the nutrient components in the dissolved and particulate fractions is instead the same defined for BACT1 (eq. 2.3.8).

### 2.3.6.2. Nutrient release and uptake

The Nutrient release and uptake parameterization is the same described for the BACT1 version (see Sec. 2.3.4.2)

### 2.3.6.3. Excretion

This version also defines a bacterial first-order excretion of carbohydrates

$$\left. \frac{dB_c}{dt} \right|_{R_c^{(2)}}^{rel} = \max \left( 0, 1 - \frac{B_p/B_c}{P_B^{opt}}, 1 - \frac{B_n/B_c}{n_B^{opt}} \right) v_B B_c \quad (2.3.19)$$

based on the optimal nutrient content and the constant relaxation time scale  $v_B$ . The release of semi refractory DOC is assumed to be at constant rate ( $d^{-1}$ ), assumed to be proportional to the activity respiration rates:

$$\left. \frac{dB_c}{dt} \right|_{R_c^{(3)}}^{rel} = \beta_B \sum_{j=1,2,3,6} \left. \frac{dB_c}{dt} \right|_{R_c^{(j)}}^{upt} \quad (2.3.20)$$

where  $\beta_B$  is the constant fraction of renewal of capsular material, usually equivalent to about 1/4 of the respiration rate (Stoderegger and Herndl, 1998). Note that this parameter must be set by the user and a warning is issued if the resulting bacterial growth efficiency is too low.

## 2.4. Zooplankton

Zooplankton is subdivided into microzooplankton and mesozooplankton with 2 sub-groups defined for each component:

- carnivorous mesozooplankton  $Z_i^{(3)}$ ;
- omnivorous mesozooplankton  $Z_i^{(4)}$ , mainly comprising calanoid copepods ;
- microzooplankton  $Z_i^{(5)}$ , representing the biomass concentration of microzooplankton with a ESD in the range 20-200  $\mu\text{m}$ , excluding flagellates and naupliar/larval stages of multicellular zooplankton or meroplanktonic larvae of benthic organisms;

- heterotrophic nanoflagellates  $Z_i^{(6)}$ , protozoa with dimensions between 2 and 20  $\mu\text{m}$ , mainly grazing upon picophytoplankton and bacteria.

Mesozooplankton is operationally defined in the model as any zooplankton between 200  $\mu\text{m}$  and 3 to 4 cm long as an adult, also embracing many species that are traditionally considered part of the microzooplankton when in juveniles stages (Broekhuizen et al., 1995). The BFM core contains a specific parameterization for microzooplankton and mesozooplankton, but the formal description is presented for the generic zooplankton as in Vichi et al. (2007b). The zooplankton parameterization is modified from Baretta-Bekker et al. (1995) and Broekhuizen et al. (1995) and it includes the processes of growth due to ingestion and the loss terms due to excretion/egestion, mortality, respiration and predation. Each zooplankton group comprises 3 constituents for C, N and P content as shown in Eq. Box 2.4, however the model is constructed to reduce the parameterizations to C-based dynamics assuming constant nutrient to carbon ratios (see Sec. 7.4).

Si and chl are currently not included as constituents for zooplankton, because biogenic silica in the form of frustules is directly egested by zooplankters and chl is a negligible part of C and N in the total biomass of preys.

### 2.4.1. Food availability

The total amount of food available to zooplankton is computed considering the set of possible preys  $X_i \in \{P_i^{(j)}, B_i, Z_i^{(j)}\}$  as the vector  $F_i = \sum_X \delta_{Z,X} e_{Z,X} X_i$ , where  $\delta_{Z,X}$  is the availability of prey  $X_i$  for predator  $Z$  and  $e_{Z,X}$  is the capture efficiency. The product of the latter terms gives the total preference. There are many definitions of preferences in the literature, and we have used concepts from Gentleman et al. (2003) and Gibson et al. (2005) to combine the parameterizations described in Baretta-Bekker et al. (1995) for microzooplankton and in Broekhuizen et al. (1995) for mesozooplankton. Availability represents the suitability

## 2. The pelagic plankton model

---

### Equation Box 2.4 Zooplankton equations.

---

$$\left. \frac{dZ_c}{dt} \right|_{bio} = \sum_{X=P,Z} \left. \frac{dZ_c}{dt} \right|_{X_c}^{prd} - \sum_{j=1,6} \left. \frac{dZ_c}{dt} \right|_{R_c^{(j)}}^{rel} - \left. \frac{dZ_c}{dt} \right|_{O^{(3)}}^{rsp} - \sum_{k=4,5,6} \left. \frac{dZ_c}{dt} \right|_{Z_c^{(k)}}^{prd} \quad (2.4.1a)$$

$$\left. \frac{dZ_n}{dt} \right|_{bio} = \frac{F_n}{F_c} \sum_{X=P,Z} \left. \frac{dZ_c}{dt} \right|_{X_c}^{prd} - \sum_{j=1,6} \left. \frac{dZ_n}{dt} \right|_{R_n^{(j)}}^{rel} - \left. \frac{dZ_n}{dt} \right|_{N^{(4)}}^{rel} - \frac{Z_n}{Z_c} \sum_{k=4,5,6} \left. \frac{dZ_c}{dt} \right|_{Z_c^{(k)}}^{prd} \quad (2.4.1b)$$

$$\left. \frac{dZ_p}{dt} \right|_{bio} = \frac{F_p}{F_c} \sum_{X=P,Z} \left. \frac{dZ_c}{dt} \right|_{X_c}^{prd} - \sum_{j=1,6} \left. \frac{dZ_p}{dt} \right|_{R_p^{(j)}}^{rel} - \left. \frac{dZ_p}{dt} \right|_{N^{(1)}}^{rel} - \frac{Z_p}{Z_c} \sum_{k=4,5,6} \left. \frac{dZ_c}{dt} \right|_{Z_c^{(k)}}^{prd} \quad (2.4.1c)$$

---

<i>Symbol</i>	<i>Code</i>	<i>Units</i>	<i>Description</i>
$Q_{10z}$	p_q10	(-)	Characteristic Q10 coefficient
$h_z^F$	p_chuc	mg C m <sup>-3</sup>	Michaelis constant for total food ingestion
$\mu_z$	p_minfood	mg C m <sup>-3</sup>	Feeding threshold
$r_{0z}$	p_sum	d <sup>-1</sup>	Potential specific growth rate
$\delta_{z,B}$	p_paPBA(z,p)	(-)	Availability of pelagic bacteria <i>B</i> to zooplankton <i>Z</i>
$\delta_{z,P}$	p_paPPY(z,p)	(-)	Availability of phytoplankton <i>P</i> to zooplankton <i>Z</i>
$\delta_{z,Z}$	p_paMIZ(z,p)	(-)	Availability of microzooplankton <i>P</i> to zooplankton <i>Z</i>
$b_z$	p_srs	d <sup>-1</sup>	Basal specific respiration rate
$\eta_z$	p_pu	(-)	Assimilation efficiency
$\beta_z$	p_pu_ea	(-)	Excreted fraction of uptake
$\epsilon_z^c$	p_pe_R1c	(-)	Partition between dissolved and particulate excretion of C
$\epsilon_z^n$	p_pe_R1n	(-)	Partition between dissolved and particulate excretion of N
$\epsilon_z^p$	p_pe_R1p	(-)	Partition between dissolved and particulate excretion of P
$n_z^{opt}, p_z^{opt}$	p_qncMIZ, p_qpcMIZ	mmolN mgC <sup>-1</sup> , mmolP mgC <sup>-1</sup>	Maximum nutrient quota
$v_z$	1	d <sup>-1</sup>	Specific rate of nutrients and carbon excretion
$d_{0z}$	p_sd	d <sup>-1</sup>	Specific mortality rate
$d_z^o$	p_sdo	d <sup>-1</sup>	Oxygen-dependent specific mortality rate
	p_chro	mmolO2 m <sup>-3</sup>	Half saturation value for oxygen

---

Table 2.5.: Mathematical and code symbols, units and description of the microzooplankton parameters (namelist Pelagic\_Ecology.nml: MicroZoo\_parameters).

<i>Symbol</i>	<i>Code</i>	<i>Units</i>	<i>Description</i>
$Q_{10Z}$	p_q10	(-)	Characteristic Q10 coefficient
$r_{0Z}$	p_sum	$d^{-1}$	Potential specific growth rate
$v_z$	p_vum	$m^3 \text{ mg C}^{-1} d^{-1}$	Specific search volume
$\delta_{z,p}$	p_paPPY(z,p)	(-)	Availability of phytoplankton $P$ to zooplankton $Z$
$\delta_{z,z}$	p_paMIZ(z,p)	(-)	Availability of microzooplankton $P$ to zooplankton $Z$
$\delta_{z,z}$	p_paMEZ(z,p)	(-)	Availability of mesozooplankton $P$ to zooplankton $Z$
$b_z$	p_srs	$d^{-1}$	Basal specific respiration rate
$\eta_z$	p_puI	(-)	Assimilation efficiency
$\beta_z$	p_peI	(-)	Excreted fraction of uptake (faeces production)
$n_z^{opt}, p_z^{opt}$	p_qncMEZ, p_qpcMEZ	$\text{mmolN mgC}^{-1},$ $\text{mmolP mgC}^{-1}$	Maximum nutrient quota
$v_z$	1	$d^{-1}$	Specific rate of nutrients and carbon excretion
$d_{0Z}$	p_sd	$d^{-1}$	Specific mortality rate
$d_z^{dns}$	p_sdo	$m^3 \text{ mgC}^{-1} d^{-1}$	Density-dependent specific mortality rate
$\gamma_z$	p_sds	(-)	Exponent for density dependent mortality
	p_clO2o	$\text{mmolO}_2 \text{ m}^{-3}$	Half saturation value for oxygen

Table 2.6.: Mathematical and code symbols, units and description of the mesozooplankton parameters (namelist Pelagic\_Ecology.nml: MesoZoo\_parameters).

of the prey and is assumed to be mostly dependent on the prey's nominal dimensions. Capture efficiency (or relative preference) is also a non-dimensional factor which is set to 1 for mesozooplankton and it is density-dependent in microzooplankton,  $e_{z,x} = \frac{X_c}{X_c + \mu_z}$ , according to the threshold half-saturation density  $\mu_z$  ( $\mu_z = 0$  for mesozooplankton).

### 2.4.2. Ingestion

The first term on the right hand side of eq. (2.4.1a) is the total carbon ingestion, which corresponds to the sum of all the predation loss terms in the carbon equations of the other functional groups preyed by zooplankton. Applying the inter-functional group conversion defined in eq. (1.0.2), the rate term for each predation processes is parameterized with a Type 2 formulation (Gentleman et al., 2003),

$$\left. \frac{dZ_c}{dt} \right|_{X_c}^{prd} = - \left. \frac{dX_c}{dt} \right|_{Z_c}^{prd} = f_z^T r_z^0 \frac{\delta_{z,x} e_{z,x} X_c}{F_c} \frac{F_c}{F_c + h_z^E} Z_c \quad (2.4.2)$$

which is traditionally rewritten in terms of the specific search volume in the case of mesozoo-

plankton ( $h_z^E = \frac{r_{0z}}{v_z}$ ), because this parameter is generally available in the literature. For brevity, in the zooplankton equations we will use the following notation to indicate the total ingestion rate in units of each constituent:

$$I_j = \sum_X \left. \frac{dZ_j}{dt} \right|_{X_j}^{prd} \quad j = c, n, p. \quad (2.4.3)$$

### 2.4.3. Excretion/egestion

Metabolic rates in zooplankton are assumed to be closely coupled to growth, therefore total ingested carbon is used part for net production, part for respiration and the remainder is egested/excreted. The parameters that can be measured in laboratory experiments are net growth efficiency  $\eta_z$  and the egested portion of ingested material  $\beta_z$ . The ingestion rate in eq. (2.4.3) is not directly affected by prey quality in our present formulation, although this process appears to modulate zooplankton feeding rates substantially (cf. Mitra and Flynn, 2005). Nevertheless, the definition of constant (optimal) nutrient quota in zooplankton (Baretta-Bekker et al.,

## 2. The pelagic plankton model

1997), equivalent to the Threshold Elemental Ratios of Andersen et al. (2004, TER), implies that the ingestion of low-quality (i.e. nutrient-poor) food lead to the disposal of the ingested carbon in excess, thus effectively limiting biomass growth.

On the other hand, an excess of nutrients, as for instance due to the ingestion of phytoplankton under “luxury uptake” conditions, leads to an increase of the nutrient remineralization rates as shown below in eqs. (2.4.14-2.4.15). The release of extra C is parameterized as an increase of the egestion rates of organic carbon compounds or, alternatively, by increasing the respiration rates. Both processes are well documented in freshwater zooplankton (Frost et al., 2004; Anderson, 2005) and we have decided to parameterize increased excretion rates. The two pathways are equivalent from the point of view of internal element regulation in zooplankton, but the consequences of one choice or another on the biogeochemical cycling of carbon are still to be investigated both experimentally and in model studies.

The carbon loss term in (2.4.1a) thus represents the sum of the activity excretion/egestion (higher for mesozooplankton because of sloppy feeding), the mortality rates and the nutrient-limited excretion of organic carbon. For the microzooplankton the carbon loss term reads:

$$\sum_{j=1,6} \frac{dZ_c}{dt} \Big|_{R_c^{(j)}}^{rel} = \beta_z I_c + (d_{0z} + d_z^o(1 - f_z^o)) f_z^T Z_c \quad (2.4.4)$$

for mesozooplankton the carbon loss term reads:

$$\frac{dZ_c}{dt} \Big|_{R_c^{(6)}}^{rel} = \beta_z I_c + (d_{0z} + doxy_{0z}(1 - f_z^o)) f_z^T Z_c + d_z^{dnp} \quad (2.4.5)$$

The released fraction is further divided into particulate (faecal pellets) and dissolved organic forms using a constant percentage  $\varepsilon_z^c$  (mesozooplankton is assumed to have no dissolved products). Mortality is parameterized as senescence with a first-order rate based on a constant  $d_{0z}$ , as oxygen regulated component  $doxy_{0z}$ , and as a grazing closure by higher trophic levels not resolved in the model, which is a power function of

density valid only for mesozooplankton ( $d_z^{dnp} = 0$  for microzooplankton).

The balancing flows of C, N, P,  $Q_Z^{c,n,p}$  are computed from the actual elemental ratios of ingested material:

$$\Gamma_z^i = \frac{(1 - \beta_z) I_i}{\eta_z I_c}, \quad i = n, p \quad (2.4.6)$$

the  $(1 - \beta_z)$  factor is the assimilation fraction of element uptake. The SWITCH (see Tab. 2.7) indicates which is the limiting element, default is carbon, if the  $\Gamma_z^i$  is lower than the internal quota  $Z_i/Z_c$  indicates that i is limiting. The ratios between the  $\Gamma_z^i$  and the respective zooplankton internal elemental quota of  $Z_i/Z_c$  are cross-compared, the lowest defines the most limiting element i. For example in the case of nitrogen limitation (N column Tab.2) the correction on carbon ( $Q_Z^c$ ) is the difference between effective ingestion of carbon ( $\eta_z I_c$ ) and the effective ingestion of nitrogen scaled by the nitrogen TER ( $n_z^{opt}$ ):

$$Q_Z^c = \eta_z I_c - \frac{(1 - \beta_z)}{n_z^{opt}} I_n, \quad (2.4.7)$$

### 2.4.4. Respiration

Taking into account the energy cost of ingestion (1 - assimilation - egestion) and basal metabolism the total respiration rate can be written as:

$$\frac{dZ_c}{dt} \Big|_{O^{(3)}}^{rsp} = (1 - \eta_z - \beta_z) I_c + b_z f_z^T Z_c \quad (2.4.8)$$

where the constant basal respiration rate  $b_z$  is also considered. The energy cost of ingestion is computed considering the following metabolic balance:

$$I_c = G_c + E_c + R_c \quad (2.4.9)$$

where Ingestion ( $I$ ) is partitioned in Growth ( $G$ ), Excretion ( $E$ ) and Respiration ( $R$ ). Assimilation efficiency  $\eta_z$  is:

$$\eta_z = \frac{G_c}{I_c} \quad (2.4.10)$$

and excretion is:

Limiting Element ->	C	N	P
SWITCH	default	if $\frac{\Gamma_Z^n}{Z_N/Z_C} < \frac{\Gamma_Z^p}{Z_P/Z_C}$ and $\frac{\Gamma_Z^n}{Z_N/Z_C} < 1$	if $\frac{\Gamma_Z^p}{Z_P/Z_C} < \frac{\Gamma_Z^n}{Z_N/Z_C}$ and $\frac{\Gamma_Z^p}{Z_P/Z_C} < 1$
$Q_Z^c$	0	$\eta_Z I_c - \frac{(1-\beta_Z)}{n_Z^{opt}} I_n$	$\eta_Z I_c - \frac{(1-\beta_Z)}{p_Z^{opt}} I_p$
$Q_Z^n$	$(1-\beta_Z) I_n - n_Z^{opt} \eta_Z I_c$	0	$(1-\beta_Z) I_n - n_Z^{opt} \eta_Z (I_c - Q_Z^c)$
$Q_Z^p$	$(1-\beta_Z) I_p - p_Z^{opt} \eta_Z I_c$	$(1-\beta_Z) I_p - p_Z^{opt} \eta_Z (I_c - Q_Z^c)$	0

Table 2.7.: Mesozooplankton formulation to eliminate the excess of the non-limiting constituent. The SWITCH control determines whether C, P or N is the limiting element.  $\eta_Z$  is the net growth efficiency factor,  $\beta_Z$  is the egested portion of ingested material,  $n_Z^{opt}$  and  $p_Z^{opt}$  are the optimal Threshold Elemental Ratios (TERs).

$$E_c = \beta_Z I_c \quad (2.4.11)$$

after some algebra we can express R in term of I:

$$R_c = (1 - \eta_Z - \beta_Z) I_c \quad (2.4.12)$$

### 2.4.5. Excretion/egestion of organic nutrients

The nutrient dynamics for zooplankton given in eqs. (2.4.1b) and (2.4.1c) are mainly derived from carbon dynamics taking into account the nutrient content of the total food uptake. The excretion/egestion rate of organic nutrients is obtained from eq. (2.4.4):

$$\sum_{j=1,6} \frac{dZ_i}{dt} \Big|_{R^{(j)}}^{rel} = \frac{Z_i}{Z_c} \left( \beta_Z I_c + d_{0z} f_z^T Z_c + d_z^{dns} Z_c^{\gamma_Z} \right) \quad (2.4.13)$$

$i = n, p$

for microzooplankton is subsequently partitioned between particulate and dissolved matter according to the non-dimensional fraction  $\epsilon_z^i$ , which parameterizes the different distribution of nutrients between structural parts and cytoplasm. Mesozooplankton only releases particulate organic detritus.

### 2.4.6. Inorganic nutrients

The third terms on the right hand side of eqs. (2.4.1b) and (2.4.1c) parameterize the zooplankton excretion of inorganic nutrients, which occur only when the internal nutrient quota exceed the optimal quota for P and N,  $p_Z^{opt}$  and  $n_Z^{opt}$ , respectively. The following formulation is applied to microzooplankton:

$$\frac{dZ_p}{dt} \Big|_{N^{(1)}}^{rel} = v_Z^p \max \left( 0, \frac{Z_p}{Z_c} - p_Z^{opt} \right) \quad (2.4.14)$$

$$\frac{dZ_n}{dt} \Big|_{N^{(4)}}^{rel} = v_Z^n \max \left( 0, \frac{Z_n}{Z_c} - n_Z^{opt} \right) \quad (2.4.15)$$

and the time scales of excretion are controlled by the specific constant rates  $v_Z^p$  and  $v_Z^n$ . The excretion is in the form of phosphate and urea, but the latter in the model is assumed to be as labile as the ammonium, therefore the rate is directed to the  $N^{(4)}$  pool. In the case of mesozooplankton the inorganic excretion is congruent with the formulation for carbon excretion (Tab.2):

$$\frac{dZ_p}{dt} \Big|_{N^{(1)}}^{rel} = d_{0z} f_z^o f_z^T Z_p + Q_Z^p \quad (2.4.16)$$

## 2. The pelagic plankton model

$$\left. \frac{dZ_n}{dt} \right|_{N^{(4)}}^{rel} = d_{0z} f_Z^o f_Z^T Z_n + Q_Z^n \quad (2.4.17)$$

## 2.5. Non-living components

### 2.5.1. Oxygen and anoxic processes

The dynamics of dissolved oxygen and carbon dioxide are important closures of global biogeochemical cycles. We do not describe here the exchange of gases at the air sea interface which is assumed to be a purely physical process and has been thoroughly investigated elsewhere, especially for CO<sub>2</sub> (Olsen et al., 2005).

Anaerobic processes and denitrification dynamics are a consequence of oxygen dynamics and are described here for completeness, although they are of limited impact in the well-oxygenated euphotic zones of the open ocean. Nevertheless, these processes are important for the sulfur cycle and for the fate of exported carbon in the meso- and bathypelagic layers of the ocean, where bacteria are the major drivers of these processes. To account for hypoxic and anoxic remineralization in the water, the original ERSEM parameterization of anaerobic processes in the sediments proposed by Ruardij and Van Raaphorst (1995) was extended to the pelagic system by Vichi et al. (2004). The state variable “reduction equivalents”  $N^{(6)}$  (Table 1.1 and Fig. 1.1) is an inorganic state variable containing all the reduced chemical species and assumed to be chemically equivalent to the sulphide ion HS<sup>-</sup>. The basic constituent is indicated with the letter R because this variable account for all the reduced biochemical products, although it should be mostly regarded as sulphur S. Reduction equivalents are produced as a result of bacterial anoxic respiration and are partly used for the parameterization of denitrification processes and partly for direct sulphide production.

The pelagic net production of oxygen is derived from the sum of gross primary production and community respiration rates from phytoplankton, zooplankton and bacteria, also subtracting the

losses due to pelagic chemical reactions:

$$\begin{aligned} \left. \frac{dO^{(2)}}{dt} \right|_{bio} &= \Omega_c^o \sum_{j=1}^3 \left( \left. \frac{dP_c^{(j)}}{dt} \right|_{O^{(3)}}^{gpp} - \left. \frac{dP_c^{(j)}}{dt} \right|_{O^{(3)}}^{rsp} \right) + \\ &\quad - \Omega_c^o f_B^o \left. \frac{dB_c}{dt} \right|_{O^{(3)}}^{rsp} + \\ &\quad - \Omega_c^o \sum_{j=4}^6 \left. \frac{dZ_c^{(j)}}{dt} \right|_{O^{(3)}}^{rsp} + \\ &\quad - \Omega_n^o \left. \frac{dN^{(4)}}{dt} \right|_{N^{(3)}}^{nit} - \frac{1}{\Omega_o^r} \left. \frac{dN^{(6)}}{dt} \right|_{sink_r}^{reox} \end{aligned} \quad (2.5.1)$$

All the rates are converted into oxygen units by means of constant stoichiometric coefficients. Since bacteria are active both under aerobic and anaerobic conditions the bacterial oxygen demand (eq. 2.3.4) is partitioned into oxygen consumption and reduction equivalent production by using the oxygen regulating factor  $f_B^o$  in (2.3.2). The nitrification rate is a source term of the nitrate equation (2.5.6b), and a sink term for ammonium (eq. 2.5.6c) and oxygen (eq.2.5.1). Nitrification is not explicitly resolved but parameterized with a simple first-order dependence on ammonium and oxygen concentrations:

$$\left. \frac{dN^{(4)}}{dt} \right|_{N^{(3)}}^{nit} = \Lambda_{N^{(4)}}^{nit} f_n^T \frac{O^{(2)}}{O^{(2)} + h_o} N^{(4)} \quad (2.5.2)$$

where  $\Lambda_{N^{(4)}}^{nit}$  is the constant specific nitrification rate and  $f_n^T$  a temperature regulating factor with the Q10 formulation shown in (eq. 2.1.1).

The formation of reduction equivalents is parameterized converting the biological oxygen demand of bacteria (under low oxygen conditions) into sulphide ions by using the stoichiometric coefficient  $\Omega_o^r$  as:

$$\begin{aligned} \left. \frac{dN^{(6)}}{dt} \right|_{bio} &= \Omega_o^r \Omega_c^o (1 - f_{B1}^o) \left. \frac{dB_c}{dt} \right|_{O^{(3)}}^{rsp} + \\ &\quad - \Omega_o^r \tilde{\Omega}_n^o \left. \frac{dN^{(3)}}{dt} \right|_{sink_n}^{denit} - \left. \frac{dN^{(6)}}{dt} \right|_{sink_r}^{reox} \end{aligned} \quad (2.5.3)$$



The utilization of nitrate as an electron acceptor in microbial metabolic reactions is parameterized in an indirect way. Firstly, when the oxygen level falls below the threshold level and  $f_B^o < 1$  (eq. 2.3.2), the metabolic formation of reduction equivalents begins according to the carbon mineralization rate (eq. 2.3.4). The denitrification reaction is favored with respect to the strictly anaerobic sulphate reduction, therefore a portion of this oxygen demand is redirected towards the denitrification process. In order to achieve this net effect, the changes in the redox conditions enhance the denitrification flux in the following way:

$$\left. \frac{dN^{(3)}}{dt} \right|^{denit} = \Lambda_{N^{(3)}}^{denit} f_n^T \left[ \frac{1}{\mathcal{M}_o^*} \Omega_c^o (1 - f_B^o) \left. \frac{dB_c}{dt} \right|_{O^{(3)}}^{rsp} \right] N^{(3)}. \quad (2.5.4)$$

where  $\Lambda_{N^{(3)}}^{denit}$  is the specific denitrification rate at a reference anoxic mineralization  $\mathcal{M}_o^*$ . If nitrate is still present in the water, the bacterial rate of production of reduction equivalents  $N^{(6)}$  is converted to nitrate consumption, mimicking the bacteria-mediated denitrification reactions. This chemical rate leads to a direct production of gaseous  $N_2$  in the water, which is the only time rate of change for state variable  $O^{(4)}$  in the model.

Furthermore, as long as there is some oxygen left, reduction equivalents are also quickly reoxidized at the following rate:

$$\left. \frac{dN^{(6)}}{dt} \right|_{sink_r}^{reox} = \Lambda_{N^{(6)}}^{reox} \frac{O^{(2)}}{O^{(2)} + h_o} N^{(6)} \quad (2.5.5)$$

where  $\Lambda_{N^{(6)}}^{reox}$  is the (constant) specific daily reoxidation rate, and  $h_o$  is the half-saturation oxygen concentration. When oxygen and nitrate are completely depleted the last two terms in (2.5.3) become zero and the process turns to a strict anaerobic formation of sulphide ions coupled to the availability of the organic substrate.

### 2.5.2. Dissolved inorganic nutrients

The pelagic cycles of dissolved inorganic nutrients are essential components of any biogeochemical model of the marine ecosystem. Five inor-

ganic CFFs for dissolved compounds are considered here (Fig. 1.1): phosphate, nitrate (nitrate + nitrite), ammonium and silicate with the equations shown in Box 2.5 and derived from the processes described in the previous sections.

The pelagic cycle of phosphate  $N^{(1)}$  in (eq. 2.5.6a) is affected by phytoplankton uptake (eq. 2.2.23), bacterial uptake/release (eq. 2.3.9) and excretion from zooplankton groups (eq. 2.4.14).

The pelagic processes for nitrate  $N^{(3)}$  shown in eq. (2.5.6b), involve phytoplankton uptake described in eq. (2.2.1b) and the nitrification and denitrification process parameterizations described in equations (2.5.2) and (2.5.4), respectively.

Ammonium (eq. 2.5.6c) is consumed by phytoplankton as described in eq. (2.2.23) and remineralized (or utilized) by bacteria according to the quality of the substrate and their internal content of nitrogen according to eq. (2.3.10). Zooplankton participates in the ammonium dynamics through the excretion of urea, which is assumed to be directly available in the form of ammonium, as shown in eq. (2.4.15).

The pelagic cycle of silicate is quite simple in the model because of the many uncertainties linked to the complex dynamics of this element in the water. Silicate concentration was originally only affected by diatom uptake (eq. 2.2.1e), but a simple first-order reaction parameterizing bacterial dissolution (e.g. Bidle and Azam, 2001) has been introduced accounting for the dissolution of silicate frustules as:

$$\left. \frac{dR_s^{(6)}}{dt} \right|_{N^{(5)}}^{rmn} = \Lambda_s^{rmn} f_{R^{(6)}}^T R_s^{(6)} \quad (2.5.7)$$

where  $\Lambda_s^{rmn}$  is the constant specific dissolution rate and  $f_{R^{(6)}}^T$  is the temperature regulating factor as in eq. (2.1.1), mimicking bacterial activity enhancement at higher temperatures.

Iron is made available in dissolved form through remineralization of biogenic particles produced by phytoplankton and zooplankton. The biochemical pathways of the remineralization process are not completely clear and involve both siderophores and photochemical reactions.

## 2. The pelagic plankton model

Symbol	Code	Units	Description
$\Omega_c^o$	MW_C	mmolO <sub>2</sub> mgC <sup>-1</sup>	Unit conversion factor and stoichiometric coefficient
$\Omega_n^o$	p_qon_nitri	mmolO <sub>2</sub> mmolN <sup>-1</sup>	Stoichiometric coefficient for nitrification reaction
$\tilde{\Omega}_n^o$	p_qon_dentri	mmolO <sub>2</sub> mmolN <sup>-1</sup>	Stoichiometric coefficient for denitrification reaction
$\Omega_o^r$	p_qro	mmolHS <sup>-</sup> mmolO <sub>2</sub> <sup>-1</sup>	Stoichiometric coefficient for oxic-anoxic reaction
$\Omega_n^r$	p_qro * p_qon_dentri	mmolHS <sup>-</sup> mmolN <sup>-1</sup>	Stoichiometric coefficient nitrogen-anoxic reaction
$\Lambda_{N4}^{nit}$	p_sN4N3	d <sup>-1</sup>	Specific nitrification rate at 10°C
$Q_{10n}$	p_q10N4N3	(-)	Q10 factor for nitrification/denitrification reaction
$h_o$	p_clO2o	mmolO <sub>2</sub> m <sup>-3</sup>	Half saturation for chemical processes
$h_r$	p_clN6r	mmolHS <sup>-</sup> m <sup>-3</sup>	Half saturation oxygen concentration for anoxic processes
$\Lambda_{N3}^{denit}$	p_sN3O4n	d <sup>-1</sup>	Specific denitrification rate
$\mathcal{M}_o^*$	p_rPAo	mmol O <sub>2</sub> m <sup>-3</sup> d <sup>-1</sup>	Reference anoxic mineralization rate
$\Lambda_{N6}^{reox}$	p_rOS	d <sup>-1</sup>	Specific reoxidation rate of reduction equivalents
$Q_{10N5}$	p_q10R6N5	(-)	Q10 factor for dissolution of biogenic silica
$\Lambda_s^{rmn}$	p_sR6N5	d <sup>-1</sup>	Specific dissolution rate of biogenic silica
$\varepsilon_{PAR}$	p_PAR	(-)	Fraction of Photosynthetically Available Radiation
$\lambda_w$	p_eps0	m <sup>-1</sup>	Background attenuation coefficient
$c_{R6}^{sed(6)}$	p_epsR6	m <sup>2</sup> mg C <sup>-1</sup>	C-specific attenuation coefficient of particulate detritus
$v_{R6}$	p_sediR6	m d <sup>-1</sup>	Settling velocity of particulate detritus

Table 2.8.: Chemical stoichiometric coefficients and general parameters involving pelagic components.

### Equation Box 2.5 Dissolved inorganic nutrient equations.

$$\left. \frac{dN^{(1)}}{dt} \right|_{bio} = - \sum_{j=1}^4 \left. \frac{dP_p^{(j)}}{dt} \right|_{N^{(1)}}^{upt} + f_B^p \left. \frac{dB_p}{dt} \right|_{N^{(1)}}^{upt,rel} + \sum_{k=4,5,6} \left. \frac{dZ_p^{(k)}}{dt} \right|_{N^{(1)}}^{rel} \quad (2.5.6a)$$

$$\left. \frac{dN^{(3)}}{dt} \right|_{bio} = - \sum_{j=1}^4 \left. \frac{dP_n^{(j)}}{dt} \right|_{N^{(3)}}^{upt} + \left. \frac{dN^{(3)}}{dt} \right|_{N^{(4)}}^{nit} - \left. \frac{dN^{(3)}}{dt} \right|_{sink_n}^{denit} \quad (2.5.6b)$$

$$\left. \frac{dN^{(4)}}{dt} \right|_{bio} = - \sum_{j=1}^4 \left. \frac{dP_n^{(j)}}{dt} \right|_{N^{(4)}}^{upt} + f_B^p \left. \frac{dB_n}{dt} \right|_{N^{(4)}}^{upt,rel} + \sum_{k=4,5,6} \left. \frac{dZ_n^{(k)}}{dt} \right|_{N^{(4)}}^{rel} - \left. \frac{dN^{(4)}}{dt} \right|_{N3}^{nit} \quad (2.5.6c)$$

$$\left. \frac{dN^{(5)}}{dt} \right|_{bio} = - \left. \frac{dP_s^{(1)}}{dt} \right|_{N^{(5)}}^{upt} + \left. \frac{dR_s^{(6)}}{dt} \right|_{N^{(5)}}^{rmn} \quad (2.5.6d)$$

**Equation Box 2.6** Dissolved organic matter equations

$$\left. \frac{dR_c^{(1)}}{dt} \right|_{bio} = \sum_{j=1}^3 \left. \frac{dP_c^{(j)}}{dt} \right|_{R_c^{(1)}}^{exu} - \left. \frac{dB_c}{dt} \right|_{R_c^{(1)}}^{upt} + \sum_{k=5,6} \left. \frac{dZ_c^{(k)}}{dt} \right|_{R_c^{(1)}}^{rel} \quad (2.5.8a)$$

$$\left. \frac{dR_i^{(1)}}{dt} \right|_{bio} = \sum_{j=1}^3 \left. \frac{dP_i^{(j)}}{dt} \right|_{R_i^{(1)}}^{exu} - \frac{R_i^{(1)}}{R_c^{(1)}} \left. \frac{dB_c}{dt} \right|_{R_c^{(1)}}^{upt} + \sum_{k=5,6} \frac{Z_i^{(k)}}{Z_c^{(k)}} \left. \frac{dZ_c^{(k)}}{dt} \right|_{R_c^{(1)}}^{rel} \quad i = n, p \quad (2.5.8b)$$

$$\left. \frac{dR_c^{(2)}}{dt} \right|_{bio} = \left. \frac{dP_c}{dt} \right|_{R_c^{(2)}}^{exu} - \left. \frac{dB_c}{dt} \right|_{R_c^{(2)}}^{upt} \left( + \left. \frac{dB_c}{dt} \right|_{R_c^{(2)}}^{rel} \right) \quad (2.5.8c)$$

Since all these processes are primarily bacterial-mediated, it is assumed here that dissolved Fe is released from detritus according to a first-order relationship as for silicate (2.5.7):

$$\left. \frac{dR_f^{(6)}}{dt} \right|_{N^{(5)}}^{rmn} = \Lambda_f^{rmn} f_{R^{(6)}}^T R_f^{(6)} \quad (2.5.9)$$

where  $\Lambda_f^{rmn}$  is a constant specific dissolution rate and  $f_{R^{(6)}}^T$  is the temperature dependence. Both numbers are currently unknown, and therefore they need to be adjusted by trial-and-error for balancing the iron cycle in the ocean. The inclusion of iron as an explicit component of zooplankton and bacteria may link this process to the direct excretion of organisms and bacterial regeneration activity, once the important pathways and time-scales have been properly assessed by laboratory and in situ experiments.

Dissolved inorganic iron species are scavenged onto particle surfaces owing to hydroxide precipitation. Since the concentration of iron ligands is about 0.6 nM in the deep ocean, Johnson et al. (1997) suggested that iron scavenging can be parameterized with a constant rate when the iron is above this threshold. Ligand dynamics have been further investigated by Archer and Johnson (2000); Parekh et al. (2004); Lefevre and Watson (1999), but the simplest approach as proposed by Johnson et al. (1997) and Aumont et al. (2003) has been used here:

$$\left. \frac{dN^{(7)}}{dt} \right|_{sink_f}^{scv} = \Lambda_f^{scv} \min(0, N^{(7)} - 0.6) \quad (2.5.10)$$

with a given time constant  $\Lambda_f^{scv} = \frac{1}{40} \text{ years}^{-1}$  and with the further assumption that scavenging results in adsorption onto sinking particles and consequently sequestration in the deeper layers.

### 2.5.3. Dissolved and particulate organic matter

The state variables describing dissolved organic matter shown in Box 2.6 have been introduced in Sec. 2.3 because they are tightly linked to the parameterizations of pelagic bacteria. Three biogeochemical basic constituents C, N and P and are thus described by 3 equations shown in. DOM is produced by phytoplankton, bacteria and microzooplankton and used as organic substrate by bacteria. The different degrees of lability of DOM are reflected in the nutrient content of  $R_j^{(1)}$ , which regulates bacterial uptake as shown in eq. (2.3.18), while variables  $R_c^{(2)}$  and  $R_c^{(3)}$  only contains the carbon constituent. The equation (2.5.8c) for semi-labile DOC (carbohydrates) is derived from the production terms implemented in the different bacteria parameterizations (Secs. 2.3.4, 2.3.5 and 2.3.6). Bacteria are allowed to release carbohydrates only in BACT2 and BACT3 parameterizations.

Particulate detritus is instead described by 4 equations, one for each biogeochemical basic constituent C, N, P, Si as in Box 2.7. The carbon, nitrogen and phosphorus component of particulate detritus in equations (2.5.11a) and (2.5.11b),

## 2. The pelagic plankton model

respectively, are produced by all the members of the planktonic community except bacteria, which are the only utilizers of this component according to eq. (2.3.18).

The pelagic cycle of biogenic silica is instead restricted to the release of diatom frustules through mortality and other lysis processes as in eq. (2.2.28) and via micro/mesozooplankton predation (including sloppy feeding) with the addition of the chemical dissolution shown in eq. (2.5.7).

Particulate iron dynamics are the consequence of processes described in equations (2.2.9), (2.5.9) and (2.5.10). Particulate organic Fe is also derived from zooplankton egestion and mortality. It is assumed that zooplankton is never iron-limited and the iron fraction of the ingested phytoplankton is directly egested as particulate detritus.

### 2.5.4. The carbonate system

The aquatic chemistry of inorganic carbon forms (state variable  $O^{(3)}$ ) is a further extension to the original ERSEM formulation and it is activated with the key `INCLUDE_PELCO2`. The theory of dissolved inorganic carbon chemical reactions is well understood (Zeebe and Wolf-Gladrow, 2001) and we propose here a slightly revised formulation with respect to Blackford and Burkill (2002), which also takes into account the algorithms proposed by the Ocean Carbon Model Intercomparison Project (Doney et al., 2004).

In the ocean, inorganic carbon is present in three different forms: free carbon dioxide ( $[CO_2] = [CO_2]_{aq} + [H_2CO_3]$ ), bicarbonate ion ( $HCO_3^-$ ) and carbonate ion ( $CO_3^{2-}$ ). These carbonate species reach the following equilibrium:

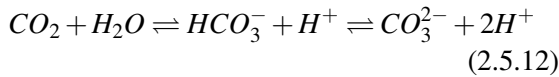

defined by the equilibrium constants  $K_1$  and  $K_2$  for the first and second reaction, respectively. The carbonate system in seawater is described in terms of 7 chemical species, i.e., free carbon dioxide ( $CO_2$ ), bicarbonate ion ( $HCO_3^-$ ), carbonate ion ( $CO_3^{2-}$ ), carbon dioxide partial pressure in seawater ( $pCO_2$ ), hydrogen ion concentration ( $pH =$

$-\log_{10}([H^+])$ ), dissolved inorganic carbon concentration ( $DIC$ ) and total alkalinity ( $TA$ ). These species are governed by the following relations:

$$K_1 = \frac{[HCO_3^-] \cdot [H^+]}{[CO_2]} \quad (2.5.13)$$

$$K_2 = \frac{[CO_3^{2-}] \cdot [H^+]}{[HCO_3^-]} \quad (2.5.14)$$

$$DIC = [CO_2] + [HCO_3^-] + [CO_3^{2-}] \quad (2.5.15)$$

$$pCO_2 = \frac{[CO_2]}{K_0} \quad (2.5.16)$$

$$\begin{aligned} TA = & [HCO_3^-] + 2[CO_3^{2-}] + [B(OH)_4^-] + \\ & + [OH^-] + [HPO_4^{2-}] + 2[PO_4^{3-}] + \\ & + [H_3SiO_4^-] - [H^+]_F - [HSO_4^-] + \\ & - [HF] - [H_3PO_4] \end{aligned} \quad (2.5.17)$$

The species appearing in this latter equation are expressed in terms of their equilibrium constants and their total elemental concentrations. Total alkalinity is therefore computed as a function of:

$$\begin{aligned} TA = f([H^+], DIC, K_1, K_2, K_w, K_b, \\ K_{1p}, K_{2p}, K_{3p}, K_{si}, K_s, K_f, bt, st, ft, \end{aligned} \quad (2.5.19)$$

$$O^{(3)}, O^{(5)}, N^{(5)}, N^{(1)}) \quad (2.5.20)$$

where  $K_1$  and  $K_2$  are the previously seen equilibrium constants for carbonic acid ( $H_2CO_3$ ) and bicarbonate ion ( $HCO_3^-$ ),  $K_0$  is the Henry's constant which regulates  $CO_2$  solubility in seawater,  $K_w$  is the ion product of water,  $K_b$  is the dissociation constant for boric acid ( $B(OH)_3$ ),  $K_{1p}$ ,  $K_{2p}$  and  $K_{3p}$  are the dissociation constants for phosphoric acid ( $H_3PO_4$ ), di-hydrogen phosphate ion ( $H_2PO_4^-$ ) and hydrogen phosphate ion ( $HPO_4^{2-}$ ) respectively,  $K_{si}$  is the dissociation constant for silicic acid ( $Si(OH)_4$ ),  $K_s$  is the dissociation constant for bisulfate ion ( $HSO_4^-$ ),  $K_f$  is the dissociation constant for hydrogen fluoride ( $HF$ ),

**Equation Box 2.7** Particulate organic detritus equations.

$$\left. \frac{dR_c^{(6)}}{dt} \right|_{bio} = \sum_{j=1}^4 \left. \frac{dP_c^{(j)}}{dt} \right|_{R_c^{(6)}}^{lys} - \left. \frac{dB_c}{dt} \right|_{R_c^{(6)}}^{upt} + \sum_{k=4}^6 \left. \frac{dZ_c^{(k)}}{dt} \right|_{R_c^{(6)}}^{rel} \quad (2.5.11a)$$

$$\left. \frac{dR_i^{(6)}}{dt} \right|_{bio} = \sum_{j=1}^4 \left. \frac{dP_i^{(j)}}{dt} \right|_{R_i^{(6)}}^{lys} - \frac{R_i^{(6)}}{R_c^{(6)}} \left. \frac{dB_c}{dt} \right|_{R_c^{(6)}}^{upt} + \sum_{k=4}^6 \frac{Z_i^{(k)}}{Z_c^{(k)}} \left. \frac{dZ_c^{(k)}}{dt} \right|_{R_c^{(6)}}^{rel} \quad i = n, p \quad (2.5.11b)$$

$$\left. \frac{dR_s^{(6)}}{dt} \right|_{bio} = \left. \frac{dP_s^{(1)}}{dt} \right|_{R_s^{(6)}}^{lys} + \frac{P_s^{(1)}}{P_c^{(1)}} \sum_{j=4}^6 \left. \frac{dP_c^{(j)}}{dt} \right|_{Z_c^{(j)}}^{prd} - \left. \frac{dR_s^{(6)}}{dt} \right|_{N^{(5)}}^{rmn} \quad (2.5.11c)$$

$bt$  is the total boron concentration ( $[B(OH)_3] + [B(OH)_4^-]$ ),  $st$  is the total sulfate concentration ( $[HSO_4^-] + [SO_4^{2-}]$ ),  $ft$  is the total fluoride concentration ( $[HF] + [F^-]$ ), and  $O^{(3)}$ ,  $O^{(5)}$ ,  $N^{(1)}$  and  $N^{(5)}$  are the model state variables for DIC, total alkalinity, total phosphorus concentration ( $[H_3PO_4] + [H_2PO_4^-] + [HPO_4^{2-}] + [PO_4^{3-}]$ ), and total silica concentration ( $[Si(OH)_4] + [H_3SiO_4^-]$ ), respectively. Note that total fluoride, sulfate and boron concentrations ( $ft$ ,  $st$  and  $bt$ ) are given as dependent on the temperature and salinity only. Currently, the model does not take into account changes of alkalinity due to calcification.

The effects of biogeochemical processes on alkalinity linked to the N cycle are taken into account with a correction to the total alkalinity value after Wolf-Gladrow et al. (2007). The uptake of 1 mole of N leads to (i) an increase of alkalinity by 1 mole when nitrate is the source, (ii) to a decrease of alkalinity by 1 mole when ammonia is used. Nitrification leads to a decrease of TA by 2 moles per mole of nitrate formed and denitrification leads to an increase of TA by 1 mole per mole of nitrate converted. Thus, considering the equations in (2.5.6b) and (2.5.6c), the source form equation for TA reads:

$$\left. \frac{dO^{(5)}}{dt} \right|_{bio} = \sum_{j=1}^4 \left. \frac{dP_n^{(j)}}{dt} \right|_{N^{(3)}}^{upt} - \sum_{j=1}^4 \left. \frac{dP_n^{(j)}}{dt} \right|_{N^{(4)}}^{upt} + \left. \frac{dN^{(3)}}{dt} \right|_{N^{(4)}}^{nit} - \left. \frac{dN^{(3)}}{dt} \right|_{sink_n}^{denit} \quad (2.5.21)$$

The equilibrium constants are also computed from temperature and salinity according to the methods described in Zeebe and Wolf-Gladrow (2001) where the total  $pH$  scale is used. The carbonate equilibrium calculation is done in units of  $mol \cdot kg^{-1}$ , therefore conversions from model units are done by taking into account the actual seawater density.

This is a five equation system (eqs. 2.5.13-2.5.17) with seven unknown variables: the system is therefore determined when two of the seven variables are known, which in this case are DIC and TA. Total alkalinity equation is used to compute  $[H^+]$  by means of the Newton-Raphson convergence method. A dedicated diagnostic variable is also introduced to store the total hydrogen ions and to allow the restart of the model from previous simulations. The other carbon species are eventually computed from the carbonate equilibrium equations.

Alternatively, the model allows the usage of a simplified computation of DIC equilibria as suggested by Follows et al. (2006), which does not imply an iterative procedure. This solution is suggested for coupled configurations because in that case the inaccuracy of the computation is less important due to the presence of advective and diffusive processes.

Finally, the biological production and consumption of  $CO_2$  considered in the model can be easily derived by collecting the first 4 terms on the right hand side of eq. (2.5.1) without considering the stoichiometric factor  $\Omega_c^o$  and taking the total

## 2. The pelagic plankton model

bacterial respiration as

$$\begin{aligned} \frac{dO^{(3)}}{dt} \Big|_{bio} = & \sum_{j=1}^3 \left( \frac{dP_c^{(j)}}{dt} \Big|_{O^{(3)}}^{gpp} - \frac{dP_c^{(j)}}{dt} \Big|_{O^{(3)}}^{rsp} \right) + \\ & - \frac{dB_c}{dt} \Big|_{O^{(3)}}^{rsp} - \sum_{k=4,5,6} \frac{dZ_c^{(k)}}{dt} \Big|_{O^{(3)}}^{rsp} \end{aligned} \quad (2.5.22)$$

The parameters of the carbonate system are

controlled with a specific namelist found in file `Carbonate_Dynamics.nml` and listed in Tab. 2.9. The namelist also allows to read an external file containing data for atmospheric concentration of inorganic carbon or to set it constant to a certain value of the mixing ratio. Atmospheric partial pressure can also be computed or read from an external file.

## 2.5. Non-living components

Parameter	Units	Description
pCO2Method	Integer Switch	Methods for computing pCO2 1 = AtmCO20* sea level pressure (slp0 in Param.nml or external input AtmSLP_N), 2 = Compute the pCO2 using the Magnus formula: Sea Level Pressure and Dew Point Temperature have to be provided
AtmCO20	ppmv	Set constant atmospheric CO2 concentration (ppm), also referred as the CO2 mixing ratio
calcAtmpCO2	Logical	Compute the atmospheric pCO2
phstart	pH	Initial guess of the seawater pH.
K1K2	Integer Switch	Acidity constants parameterization 1- Roy et al. (1993); DOE (1994); pH on total scale; 2- Mehrbach et al. (1973) refit by Dickson & Millero (1987); pH on Sea Water Scale; 3 - Mehrbach et al.(1973) refit by Lueker et al. (2000), pH on total scale; 4 - Hansson (1973b) data as refitted by Dickson and Millero (1987), pH on Sea Water Scale.
MethodCalcCO2	Integer Switch	Method for Carbonate System computation: 1 - Approximate static solution; 2 - Standard OCMIP iteration; 3 - Approximation by Follows et al. (2006).
CalcBioAlkFlag	Logical	Compute the corrections of alkalinity due to biogeochemical processes
M2XACC	Threshold	Accuracy of the iterative scheme for OCMIP (with MethodCalcCO2=2)
M2PHDELTA	pH	pH range for the root search in the OCMIP scheme (with MethodCalcCO2=2)
M2MAXIT	Integer	maximum number of iterations for OCMIP (with MethodCalcCO2=2)
Caconc0	mol m <sup>-3</sup>	Calcium ion concentration (In "Seawater : Its composition, properties and behaviour", Open University Course Team, 1995)
Canorm	Logical	Normalize Calcium ion concentration by sea water salinity
AtmCO2_N	ppmv	Read external file with atmospheric CO2 mixing ratio data.
AtmSLP_N	Pa	Read external file with Sea Level Pressure data (with pCO2Method=1 and 2).
AtmTDP_N	°C	Read external file with atmospheric Dew Point Temperature data (with pCO2Method = 2).

Table 2.9.: Parameters controlling the carbonate system (from namelist Carbonate\_Dynamics.nml)

## 2. *The pelagic plankton model*



## 3. The sea ice biogeochemical model

### 3.1. A model for sea ice biogeochemistry

Sea ice is a rich habitat for microbial community. The most abundant species found are unicellular microalgae, mostly diatoms. When sea ice forms, many organisms are either passively or actively entrapped in the salty brines. Their rate of survival in the new habitat depends on their adaptation and/or acclimation to the new environmental conditions (low temperature, high salinity and low light intensities) and on the external supply of nutrients and gases from seawater. Some organisms may die in isolated brines, some may survive or encyst, some may find a favorable habitat and actively grow. Concentrations up to 1000 mg m<sup>-3</sup> of diatom chlorophyll have been found in Antarctic sea ice (Thomas and Dieckmann, 2002).

The sea ice biogeochemical cycle is also strongly related to its oceanic counterpart. This is of extreme biological importance at the end of the ice season, when sea ice starts melting and a sea ice algae bloom occurs. The fate of this biomass depends on the rate of melting and on the vertical stability of the water column. If the stratification is high and the rate of melting is low, sea ice algae may stay long time in the upper part of the water column and may seed a pelagic phytoplankton bloom. Polar blooms represent a relevant fraction of the carbon production in some regions of the world, such as the Ross Sea and the Weddell Sea in Antarctica, and the Barents Sea in the Arctic. If the rate of melting is high and the stratification is low, the sea ice biomass may rapidly sink to the bottom of the ocean and likely become a sink for the atmospheric CO<sub>2</sub>. In both cases, the size and weight of the organisms affect the sinking velocity.

Sea ice biota has been studied for only a few decades. Few regions have been highly character-

ized, but sea ice biological variability at different temporal and spatial scales is still lacking. Sea ice is one of the largest ecosystem on earth, but is also one of the less sampled: sampling sea ice biota is in fact not an easy task. It is costly and time-consuming and often it is done in severe environmental conditions. In absence of data and remote sensing facilities, modelling can help understanding the sea ice ecosystem, as well as it can provide the wider picture of its qualitative and quantitative importance, which is still missing.

The sea ice extension of the BFM described here (BFM-SI) has been published in a series of papers (Tedesco et al., 2010, 2012; Tedesco and Vichi, 2014) and this chapter is a modified version of Tedesco and Vichi (2010). The reader interested in a full theoretical description and a review of the existing techniques for sea ice biogeochemical modelling is addressed to Tedesco and Vichi (2014). This latter paper also describes the default example available as part of the BFM presets, STANDALONE\_SEAICE.

### 3.2. Model structure

This implementation focuses on primary producers, which are the most abundant group of organisms found in sea ice and the most relevant group in terms of export of biomass to the ocean. The biogeochemical equations of the sea ice algae dynamics are written according to the formulation explained in Chapter 1.

The model layout (Fig. 3.1) takes advantage of the same biological processes of the pelagic BFM. The focus is here on primary producers, which are assumed to differently adapt to the new physical environment. The main differences between BFM and BFM-SI stand in the type and number of functional groups (Table 3.1), in the parameters assigned to several physiological and ecological

### 3. The sea ice biogeochemical model

processes (Table 3.2) and in the dimensional form they represent. While pelagic state variables are expressed in terms of their constituent per cubic meters, the BFM-SI state variables are expressed in terms of constituent per square meters. The strategy of coupling will be further described.

BFM-SI totally resolves 28 state variables (Fig. 3.1, Table 3.1):

- 2 sea ice algae functional groups (adapted diatoms and surviving sea ice algae, mostly represented by autotrophic nanoflagellates)
- 6 inorganic variables for nutrients and gases (phosphate, nitrate, ammonium, silicate, oxygen and carbon dioxide)
- 2 organic non-living groups for dissolved and particulate detritus
- 1 generic group of aerobic and anaerobic sea ice bacteria
- 1 generic group of sea ice fauna

Each state variable interacts with the others through the universal physiological and ecological processes depicted in Fig. 3.1. This component already includes parameterizations of sea ice bacteria and fauna, which follow the same dynamics as their counterpart in the pelagic realm. Nonetheless, both groups are technically available for future studies.

As for the pelagic model, nitrate is assumed here to be the sum of both nitrite and nitrate. All the nutrient:carbon ratios in chemical organic and living functional groups are allowed to vary within their given range and each component has a distinct biological time rate of change. This kind of parametrization is meant to mimic the adaptation of organisms to the diverse availability of nutrients and light observed in nature, and also allow to recycle organic matter depending on the actual nutrient content.

### 3.3. Sea ice Algae Dynamics

As a first implementation of the BFM in sea ice, 2 distinct subgroups have been chosen as represen-

tative of sea ice primary producers:

- Adapted diatoms, which are meant to be highly adapted to the environment and also show distinct skills in acclimation. They are supposed to be first light-limited and, later in the bloom, dependent on nutrient availability. They have an Equivalent Spherical Diameter (ESD) of 20-200  $\mu\text{m}$  and preyed by adult mesozooplankton ( $> 200 \mu\text{m}$ ) and microzooplankton of larger dimensions (20-200  $\mu\text{m}$ ), which are not currently present in the sea ice system, but act in the pelagic BFM when sea ice melts and algae are released in the water column. Sea ice diatoms are the main source of biogenic silica and differ from the other subgroup being their growth limited by dissolved silicate.
- Surviving sea ice algae, which may be mostly represented by autotrophic nanoflagellates, are meant to only survive in the sea ice environment, being less adapted to it and showing lower skills of acclimation. However, they may be able to grow in sea ice if the diatoms bloom is quickly exhausted - for instance, for depletion of silicate - and a sufficient amount of nutrients is still available for their growth. Their ESD is 2-20  $\mu\text{m}$  and are mainly externally preyed by pelagic microzooplankton.

The mathematical notation used here is the same defined for the pelagic BFM (Chap 1). Sea ice algae are involved in several processes: gross primary production (gpp), respiration (rsp), exudation (exu), cell lysis (lys), nutrient uptake (upt), predation (prd) and biochemical synthesis (syn). Both subgroups share the same form of primitive equations, but are differentiated in terms of the values of the physiological parameters (Table 3.2). There are 5 living CFFs that describe the constituents of the generic variable sea ice algae A (with constituents C, N, P, Si and Chl, see Table 3.1) and thus for each group we have 4 or 5 equations as shown in Equation Box 3.1:

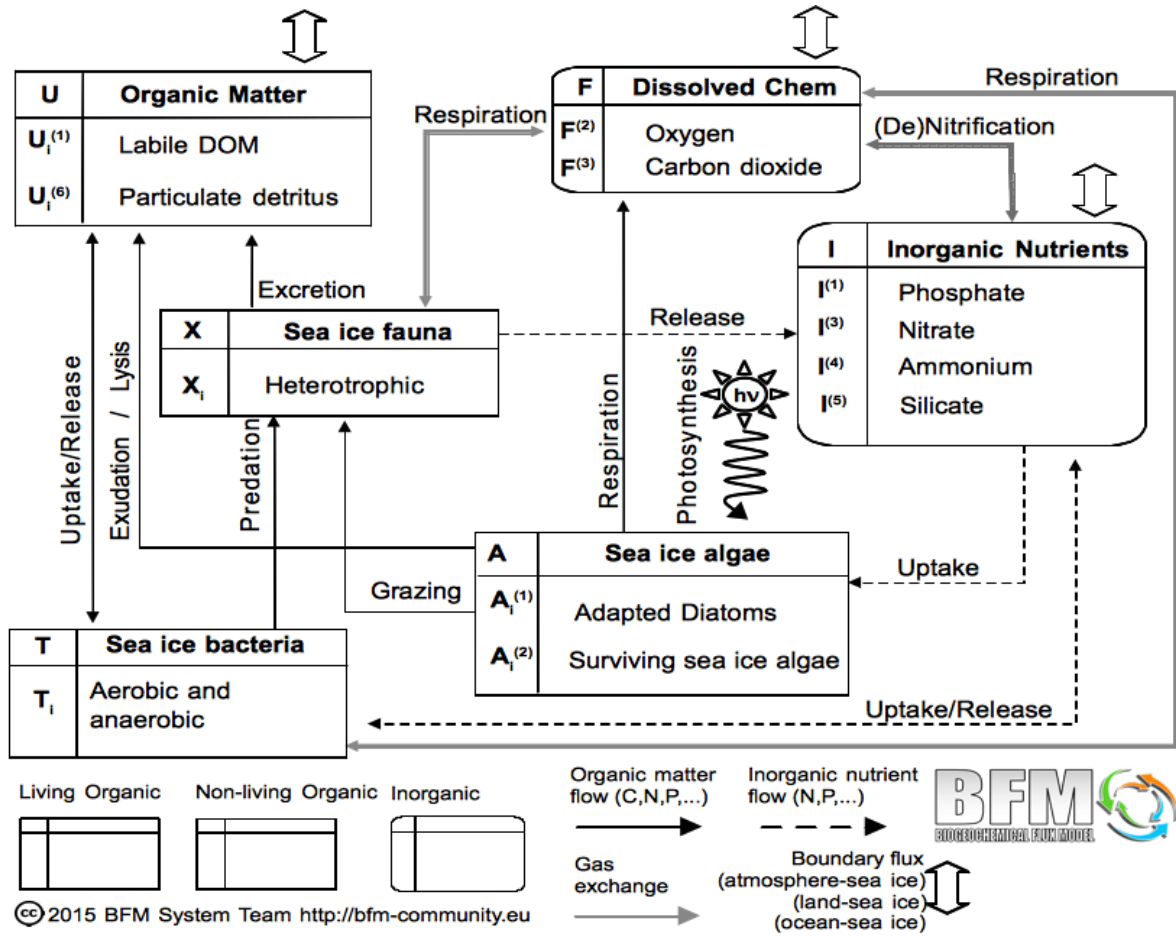

Figure 3.1.: Scheme of the state variables of BFM-SI and interactions within BFM-SI and with external systems.

The rate of change of carbon in sea ice algae depends on gross primary production, exudation, respiration, lysis and predation (Eq. 3.3.1a). Gross primary production is the rate of change of sea ice algae carbon  $A_c$  due to photosynthesis, which involves an uptake of dissolved carbon dioxide  $F^{(3)}$ . It is written as:

$$\frac{dA_c}{dt} \Big|_{F^{(3)}}^{gpp} = f_A^T f_A^E f_A^S r_A^0 A_c \quad (3.3.2)$$

where the  $r_A^0$  is the maximum specific photosynthetic rate under nutrient-replete, light saturated conditions (Table 3.2). The  $f$  functions are mul-

tiplicative, non-dimensional regulating factors for temperature, light and silicate, which vary from 0 to 1.

Temperature is regulating several physiological processes. Its effect is expressed in a non-dimensional form by  $f_A^T$ :

$$f_A^T = Q_{10}^A \frac{T-10}{10} \quad (3.3.3)$$

where  $Q_{10}^A$  is the characteristic doubling temperature parameter (Table 3.2).

Many relevant biological processes, such as potential photosynthesis, are also affected by the

### 3. The sea ice biogeochemical model

Table 3.1.: List of the sea ice model state variables. Legend: IO = Inorganic; LO = Living organic; NO = Non-living organic. The subscript  $i$  indicates the basic components of the group, e.g.  $A_i^{(1)} \equiv (A_c^{(1)}; A_n^{(1)}; A_p^{(1)}; A_s^{(1)}; A_l^{(1)})$ .

Variable	Type	Components	Description
$I^{(1)}$	IO	P	Phosphate (mmol P m <sup>-2</sup> )
$I^{(3)}$	IO	N	Nitrate (mmol N m <sup>-2</sup> )
$I^{(4)}$	IO	N	Ammonium (mmol N m <sup>-2</sup> )
$I^{(5)}$	IO	Si	Silicate (mmol Si m <sup>-2</sup> )
$F^{(2)}$	IO	O	Dissolved oxygen (mg C m <sup>-2</sup> )
$F^{(3)}$	IO	C	Carbon dioxide (mg C m <sup>-2</sup> )
$A_i^{(1)}$	LO	C N P Si Chl	Adapted diatoms (mg C m <sup>-2</sup> , mmol N-P-Si m <sup>-2</sup> , mg Chl-a m <sup>-2</sup> )
$A_i^{(2)}$	LO	C N P Chl	Surviving sea ice algae (mg C m <sup>-2</sup> , mmol N-P m <sup>-2</sup> , mg Chl-a m <sup>-2</sup> )
$T_i$	LO	C N P	Sea ice bacteria (mg C m <sup>-2</sup> , mmol N-P m <sup>-2</sup> )
$X_i$	LO	C N P	Sea ice fauna (mg C m <sup>-2</sup> , mmol N-P m <sup>-2</sup> )
$U_i^{(1)}$	NO	C N P	Dissolved organic detritus (mg C m <sup>-2</sup> , mmol N-P m <sup>-2</sup> )
$U_i^{(6)}$	NO	C N P Si	Particulate organic detritus (mg C m <sup>-2</sup> , mmol N-P-Si m <sup>-2</sup> )

non-dimensional light regulating factor  $f_A^E$ :

$$f_A^E = 1 - \exp\left(-\frac{E_{PAR}}{E_K}\right) \quad (3.3.4)$$

$\lambda_{bio}$ , where:

$$\lambda_{bio} = \sum_j^2 c_A A_l^{(j)} + c_{U(6)} U_c^{(6)}. \quad (3.3.6)$$

where  $E_{PAR}$  is the Photosynthetic Available Radiation (PAR).  $E_{PAR}$  is parametrized according to the Lambert-Beer formulation with depth-dependent extinction coefficients:

$$E_{PAR}(z) = \epsilon_{PAR} F_{sw} e^{(\lambda_s + \lambda_i)z + \int_z^0 \lambda_{bio}(z') dz'} \quad (3.3.5)$$

where  $F_{sw}$  is the short-wave surface irradiance flux and may be derived from data or from a coupled physical model, such as the one of Tedesco et al. (2009, 2010). The irradiance flux is then converted by BFM-SI from W m<sup>-2</sup> to the units of  $\mu\text{E m}^{-2} \text{s}^{-1}$  as done in the pelagic model.  $\epsilon_{PAR}$  is the coefficient determining the portion of PAR in  $F_{sw}$ . Light propagation takes into account the extinction due to the background extinction of snow/sea ice  $\lambda_{s,i}$  and due to particles in the sea ice

Thus,  $\lambda_{bio}$  takes into consideration the extinction due to sea ice algae chlorophyll and to particulate detritus, while dissolved substances and other inorganic matter are not currently taken into account. The  $c_A$  and  $c_U$  constants are the specific absorption coefficients of each suspended substance (Table 3.2).

$E_K$  is the light saturation parameter, that is the ratio between the maximum chl-*a* specific photosynthetic rate and the maximum light utilization coefficient, i.e.:

$$E_K = \frac{P_m^*}{\alpha^*}. \quad (3.3.7)$$

As for pelagic phytoplankton of BFM:

$$P_m^* = f_A^T f_A^S r_A^0 \frac{A_c}{A_l} \quad (3.3.8)$$

Table 3.2.: Ecological and physiological parameters in BFM-SI.

Symbol	A <sup>(1)</sup>	A <sup>(2)</sup>	Description
$r_0^A$	1.5	2.0	Maximum specific photosynthetic rate (d <sup>-1</sup> )
$Q_{10}^A$	2.0	2.0	Characteristic Q <sub>10</sub> coefficient (-)
$\theta_{chl}^0$	0.035	0.03	Optimal quotum chl-a:C (mg chl mg C <sup>-1</sup> )
$\alpha_{chl}^0$	1.8 e <sup>-3</sup>	3.8 e <sup>-6</sup>	Maximum light utilization coefficient (mg C (mg chl) <sup>-1</sup> mE <sup>-1</sup> m <sup>2</sup> s)
$d_s$	0.1	-	Half saturation value for Si-limitation (mmol Si m <sup>-2</sup> )
$b_A$	0.05	0.1	Basal specific respiration rate (d <sup>-1</sup> )
$\gamma_A$	0.10	0.10	Activity respiration fraction (-)
$\beta_A$	0.05	0.20	Excreted fraction of primary production (-)
$d_A^{p,n,s}$	0.1	0.2	Nutrient stress threshold (-)
$d_{O_A}$	0.1	0.1	Maximum specific lysis rate (d <sup>-1</sup> )
$a_1$	2.5 10 <sup>-3</sup>	2.5 10 <sup>-3</sup>	Specific affinity constant for P (m <sup>-2</sup> mg C <sup>-1</sup> d <sup>-1</sup> )
$a_3$	2.5 10 <sup>-3</sup>	2.5 10 <sup>-3</sup>	Specific affinity constant for N-NO <sub>3</sub> (m <sup>-2</sup> mg C <sup>-1</sup> d <sup>-1</sup> )
$a_4$	2.5 10 <sup>-3</sup>	2.5 10 <sup>-3</sup>	Specific affinity constant for N-NH <sub>4</sub> (m <sup>-2</sup> mg C <sup>-1</sup> d <sup>-1</sup> )
$s_{A(1)}^{opt}$	0.03	-	Standard Si:C ratio in sea ice diatoms (mmol Si mg C <sup>-1</sup> )
$s_{A(1)}^{max}$	0.085	-	Maximum Si:C ratio in sea ice diatoms (mmol Si mg C <sup>-1</sup> )
$p_A^{min}$	1.97 10 <sup>-4</sup>	1.97 10 <sup>-4</sup>	Minimum phosphorus quota (mmol P mgC <sup>-1</sup> )
$p_A^{opt}$	7.86 10 <sup>-4</sup>	7.86 10 <sup>-4</sup>	Optimal phosphorus quota (mmol P mgC <sup>-1</sup> )
$p_A^{max}$	1.57 10 <sup>-3</sup>	1.57 10 <sup>-3</sup>	Maximum phosphorus quota (mmol P mgC <sup>-1</sup> )
$n_A^{min}$	3.78 10 <sup>-4</sup>	3.78 10 <sup>-4</sup>	Minimum nitrogen quota (mmol N mgC <sup>-1</sup> )
$n_A^{opt}$	1.26 10 <sup>-3</sup>	1.26 10 <sup>-3</sup>	Optimal nitrogen quota (mmol N mgC <sup>-1</sup> )
$n_A^{max}$	2.52 10 <sup>-3</sup>	2.52 10 <sup>-3</sup>	Maximum nitrogen quota (mmol N mgC <sup>-1</sup> )
$c_A$	10.0 e <sup>-3</sup>	10.0 e <sup>-3</sup>	Specific absorption coefficient for chlorophyll-a (m <sup>2</sup> (mg Chl-a) <sup>-1</sup> )
$c_U$	0.1 e <sup>-3</sup>	0.1 e <sup>-3</sup>	Specific absorption coefficient for detritus (m <sup>2</sup> (mg C) <sup>-1</sup> )
$\Omega_c^o$	$\frac{1}{12}$	$\frac{1}{12}$	Unit conversion factor and stoichiometric coefficient (mmol O <sub>2</sub> mgC) <sup>-1</sup>

### 3. The sea ice biogeochemical model

#### Equation Box 3.1 Sea ice algae equations

$$\frac{dA_c}{dt} = - \sum_{j=1,6} \frac{dA_c}{dt} \Big|_{U_c^{(j)}}^{lys} - \frac{dA_c}{dt} \Big|_{F^{(3)}}^{gpp} - \frac{dA_c}{dt} \Big|_{U_c^{(1)}}^{exu} - \frac{dA_c}{dt} \Big|_{F^{(3)}}^{resp} \quad (3.3.1a)$$

$$\frac{dA_n}{dt} = \sum_{j=3,4} \frac{dA_n}{dt} \Big|_{I^{(j)}}^{upt} - \sum_{j=1,6} \frac{dA_n}{dt} \Big|_{U_n^{(j)}}^{lys} \quad (3.3.1b)$$

$$\frac{dA_p}{dt} = \frac{dA_p}{dt} \Big|_{I^{(1)}}^{upt} - \sum_{j=1,6} \frac{dA_p}{dt} \Big|_{U_p^{(j)}}^{lys} \quad (3.3.1c)$$

$$\frac{dA_s^{(1)}}{dt} = \frac{dA_s^{(1)}}{dt} \Big|_{I^{(5)}}^{upt} - \frac{dA_s^{(1)}}{dt} \Big|_{U_s^{(6)}}^{lys} \quad (3.3.1d)$$

$$\frac{dA_l}{dt} = \theta_{chl} \left( \frac{dA_c}{dt} \Big|_{F^{(3)}}^{gpp} - \frac{dA_c}{dt} \Big|_{U_c^{(1)}}^{exu} \right) - \left( \frac{dA_c}{dt} \Big|_{F^{(3)}}^{rsp} + \frac{dA_c}{dt} \Big|_{U_c^{(6)}}^{lys} \right) \frac{A_l}{A_c} \quad (3.3.1e)$$

$$\alpha^* = f_A^T f_A^s \alpha_{chl}^0 \quad (3.3.9)$$

where  $f_A^T$  is the regulating factor for temperature,  $f_A^s$  is the regulating factor for silicate,  $r_A^0$  is the maximum specific photosynthetic rate under nutrient-replete, light-saturated conditions and  $\alpha_{chl}^0$  is the maximum slope of the production-irradiance curve at optimal conditions (Table 3.2).

The  $f_A^s$  is parametrized as an external limiting factor with a Michaelis-Menten form:

$$f_A^s = \frac{I^{(5)}}{I^{(5)} + d_s} \quad (3.3.10)$$

where  $d_s$  is the Michaelis-Menten constant for SiO<sub>2</sub> uptake inhibition (Table 3.2).

The exudation rate of Eq. (3.3.1a) reads:

$$\frac{dA_c}{dt} \Big|_{U_c^{(1)}}^{exu} = [\beta_A + (1 - \beta_A)(1 - f_A^{n,p})] \frac{dA_c}{dt} \Big|_{F^{(3)}}^{gpp} \quad (3.3.11)$$

where  $\beta_A$  is a constant fraction of carbon uptake (Table 3.2) and  $f_A^{n,p}$  is a Liebig-like regulating factor for internal nutrient ratio:

$$f_A^{n,p} = \min \left( \frac{A_n/A_c - n_A^{min}}{n_A^{opt} - n_A^{min}}, \frac{A_p/A_c - p_A^{min}}{p_A^{opt} - p_A^{min}} \right) \quad (3.3.12)$$

where  $n(p)_A^{opt}$  is the nitrate(phosphate) optimal ratio, while  $n(p)_A^{min}$  is the nitrate(phosphate) minimum quota (Table 3.2).

The respiration rate of Eq. (3.3.1a) is written as:

$$\frac{dA_c}{dt} \Big|_{F^{(3)}}^{rsp} = f_A^T b_A A_c + \gamma_A \left( \frac{dA_c}{dt} \Big|_{F^{(3)}}^{gpp} - \frac{dA_c}{dt} \Big|_{U_c^{(1)}}^{exu} \right) \quad (3.3.13)$$

where  $f_A^T$  is the metabolic regulating factor for temperature,  $b_A$  is a constant specific rate of respiration and  $\gamma_A$  is a fraction of the assimilated production (Table 3.2).

The loss of carbon via lysis of Eq. (3.3.1a) is written as:

$$\sum_{j=1,6} \frac{dA_c}{dt} \Big|_{U_c^{(j)}}^{lys} = \frac{1}{f_A^{p,n} + d_A^{p,n}} d_{O_A} A_c \quad (3.3.14)$$

where  $d_A^{p,n}$  is the nutrient stress threshold and  $d_{O_A}$  is the maximum specific lysis rate (Table 3.2).

### 3.4. Nutrient Supply and Dynamics

The chlorophyll rate of change of Eq. (3.3.1e) is due to chlorophyll synthesis. The net chlorophyll synthesis is a function of acclimation to light conditions, nutrient availability and turnover rate. As in BFM, it is assumed that nutrient-stressed cells releasing substantial amounts of dissolved organic carbon tend to regulate their internal chl:C ratio in order to avoid unconstrained decreases.

The rate of change of net photosynthesis is thus primarily controlled by the dynamical chl:C ratio  $\theta_{chl}$  proposed by Geider et al. (1998), which regulates the amount of chl-*a* in the cell according to a non-dimensional ratio between the realized photosynthetic rate in Eq. (3.3.1e) and the maximum potential photosynthesis, i.e.:

$$\theta_{chl} = \theta_{chl}^0 \frac{f_A^E r_A^0 A_c}{\alpha_{chl}^0 E_{PAR} A_l} \quad (3.3.15)$$

where  $\theta_{chl}^0$  is the maximum quorum chl-*a*:C and  $\alpha_{chl}^0$  is the maximum slope of the production-irradiance curve at optimal growth conditions (Table 3.2). The same considerations about down-regulation and chlorophyll losses as detailed in Sec. 2.2.6 for phytoplankton are valid for sea ice algae.

### 3.4. Nutrient Supply and Dynamics

Nutrients supply for algal growth comes from the mixed layer up to the ice sheet for sustaining bottom communities, but also from snow deposition through brine drainage for surface communities and from *in situ* regeneration processes.

Even in isolated brine pockets, bacteria, heterotrophic protozoa and small metazoans have been shown to regenerate the major nutrients (Arrigo et al., 1995), but not silicate. Silicate dissolution and regeneration may be slower than demand and can be the major limiting factor for diatoms growth (Lizotte and Sullivan, 1991), shifting the community from being diatom-dominated to flagellates-dominated (Dieckmann et al., 1991). The slow regeneration of silicate in sea ice is parametrized

in BFM-SI as a smaller value for the half saturation of silica and a larger value for the standard Si:C quorum in adapted diatoms (Table 3.2).

The boundary fluxes are currently added as additional source terms to the biogeochemical equations and solved explicitly. For instance, in the case of an inorganic nutrient in sea ice (e.g. nitrate,  $I^{(3)}$ ), the complete equation is written as

$$\frac{dI^{(3)}}{dt} = \frac{dA_n^{(1)}}{dt} \Big|_{I^{(3)}}^{upt} + \frac{dA_n^{(2)}}{dt} \Big|_{I^{(3)}}^{upt} + \frac{dI^{(3)}}{dt} \Big|_{N^{(3)}}^{flux} \quad (3.4.1)$$

where the first two terms on the right hand side represent the uptake from sea ice algae and the last one is the flux of nutrient at the boundaries. The external mechanisms of nutrients replenishment (exchange with the ocean and atmospheric deposition) will be analyzed in the next sections.

The uptake of nitrogen and phosphorous by algae (Eq. 3.4.1) is regulated by a Droop kinetics:

$$\sum_{i=3,4} \frac{dA_n}{dt} \Big|_{I^{(i)}}^{upt} = \min \left( \left( a_A^3 I^{(3)} + a_A^4 I^{(4)} \right) A_c, n_A^{opt} G_A + f_A^T r_A^0 \left( n_A^{max} - \frac{A_n}{A_c} \right) A_c \right) \quad (3.4.2)$$

$$\frac{dA_p}{dt} \Big|_{I^{(1)}}^{upt} = \min \left( a_A^1 I^{(1)} A_c, p_A^{opt} G_A + f_A^T r_A^0 \left( p_A^{max} - \frac{A_p}{A_c} \right) A_c \right) \quad (3.4.3)$$

where the  $a$  constants are the membrane affinity for nitrate, ammonium and phosphate (Table 3.2).

The uptake of silicate is, instead, only function of the maximum Si:C ratio  $s_{A^{(1)}}^{max}$  and of the net production  $G_{A^{(1)}}$  of Eq. (3.3.1a):

$$\frac{dA_s}{dt} \Big|_{I^{(5)}}^{upt} = s_{A^{(1)}}^{max} G_{A^{(1)}} \quad (3.4.4)$$

Whenever sea ice algae carbon is lost by lysis, a proportional loss is found for algae nutrient content and is distributed between a dissolved and a

### 3. The sea ice biogeochemical model

particulate fraction. For instance, the equations of the lysis rate for phosphorous are:

$$\left. \frac{dA_p}{dt} \right|_{U_p^{(6)}}^{lys} = p_A^{min} \left. \frac{\partial A_c}{\partial t} \right|_{U_c^{(6)}}^{lys} \quad (3.4.5)$$

$$\left. \frac{dA_p}{dt} \right|_{U_p^{(1)}}^{lys} = \frac{A_p}{A_c} \sum_{j=1,6} \left. \frac{\partial A_c}{\partial t} \right|_{U_c^{(j)}}^{lys} - \left. \frac{\partial A_p}{\partial t} \right|_{U_p^{(6)}}^{lys} \quad (3.4.6)$$

Silicate is instead only released in particulate form:

$$\left. \frac{\partial A_s^{(1)}}{\partial t} \right|_{U_s^{(6)}}^{lys} = \frac{A_s^{(1)}}{A_c^{(1)}} \left. \frac{\partial A_c^{(1)}}{\partial t} \right|_{U_c^{(6)}}^{lys} \quad (3.4.7)$$

### 3.5. Gases and Detritus

The following equations are derived by combining terms from the previous sections in order to ensure mass conservation. The net production of oxygen is due to the gross primary production and to algae respiration rates:

$$\left. \frac{\partial F^{(2)}}{\partial t} \right|_{bio} = \Omega_c^o \sum_{j=1}^2 \left( \left. \frac{\partial A_c^{(j)}}{\partial t} \right|_{F^{(3)}}^{gpp} - \left. \frac{\partial A_c^{(j)}}{\partial t} \right|_{F^{(3)}}^{rsp} \right)$$

where  $\Omega_c^o$  is the stoichiometric conversion factor to oxygen units in respiration and photosynthesis (Table 3.2).

Dissolved organic matter (DOM,  $U_i^{(1)}$  in BFM-SI) is a non-living functional group including C, N and P constituents. In this current implementation, DOM is produced by sea ice algae (Eq. 3.3.11), though in the complete setup shown in Fig. 3.1, DOM will be produced also by sea ice bacteria and microzooplankton:

$$\left. \frac{\partial U_c^{(1)}}{\partial t} \right|_{bio} = \sum_{j=1}^2 \left. \frac{\partial A_c^{(j)}}{\partial t} \right|_{U_c^{(1)}}^{exu} \quad (3.5.1)$$

$$\left. \frac{\partial U_i^{(1)}}{\partial t} \right|_{bio} = \sum_{j=1}^2 \left. \frac{\partial A_i^{(j)}}{\partial t} \right|_{U_i^{(1)}}^{exu} \quad i = n, p. \quad (3.5.2)$$

Particulate organic matter (POM,  $U_i^{(6)}$  in BFM-SI) is made of C, N, P and Si:

$$\left. \frac{\partial U_c^{(6)}}{\partial t} \right|_{bio} = \sum_{j=1}^2 \left. \frac{\partial A_c^{(j)}}{\partial t} \right|_{U_c^{(6)}}^{lys} \quad (3.5.3)$$

$$\left. \frac{\partial U_i^{(6)}}{\partial t} \right|_{bio} = \sum_{j=1}^2 \left. \frac{\partial A_i^{(j)}}{\partial t} \right|_{U_i^{(6)}}^{lys} \quad i = n, p, s \quad (3.5.4)$$

where the silicate component of POM is only valid for the release of sea ice diatoms frustules.

### 3.6. The coupling strategy

A full description of the coupling issues is given in Tedesco and Vichi (2014); here we briefly mention some major aspects. The construction of a biological system in sea ice implies the coupling with the underlying biology of the ocean. BFM-SI is in fact coupled to a simplified version of the pelagic lower trophic levels in a surface layer of ice-covered oceans. The standard pelagic BFM has been simplified in a way that every sea ice group has its own pelagic counterpart and there is no loss of material between the two systems (Fig. 3.2). The number of functional groups is reduced and the total number of state variables computed are 34. The included groups and subgroups in the pelagic BFM are:

- 2 phytoplankton (diatoms and autotrophic nanoflagellates)
- 3 zooplankton (omnivorous mesozooplankton, microzooplankton and heterotrophic nanoflagellates)
- 1 pelagic bacteria
- 9 inorganic variables for nutrients and gases (phosphate, nitrate, ammonium, silicate, oxygen, carbon dioxide)
- 2 organic non-living variables for dissolved and particulate detritus.



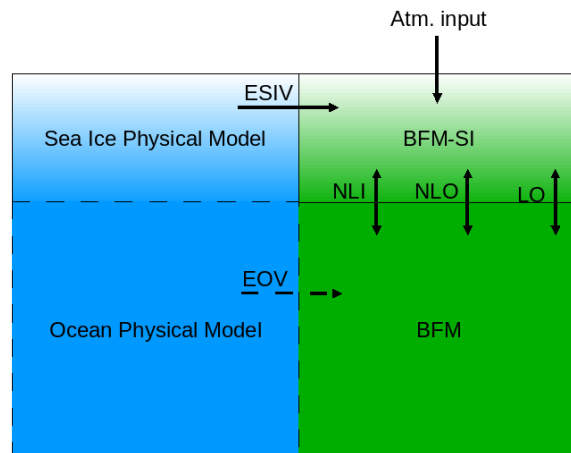

Figure 3.2.: Structure of the current coupling between physics and biogeochemistry (boxes with continuous line). The sea ice physical model passes offline the Environmental Sea Ice Variables (ESIV) to BFM-SI. BFM-SI is online coupled to BFM through the exchange of Non Living Inorganic (NLI), Non Living Organic (NLO) and Living Organic (LO) matter. Boxes with dashed lines represent the possibility for the sea ice physical model to be also coupled to an ocean physical model, which would pass the Environmental Ocean Variables (EOV) to BFM.

Differently to BFM-SI, the pelagic zooplankton includes 3 different subgroups and mesozooplankton may effectively control the fate of the sea ice algae released into the water and the magnitude of the phytoplankton bloom. Consequently, the diversity of feeding behaviors of zooplankton is maintained.

The exchange of matter between the ocean system and the sea ice system will be the subject of the next section. We focus here on the coupling strategy. BFM-SI has been built as a layer model, in a similar way as the benthic component of BFM is designed. A layer model means that the model is two-dimensional (concentrations are expressed in units of mass per square meters): all the members of a generic layer of the system, as for instance the benthic oxic layer, have to be thought as their constituents are homogeneously distributed on a stratum at the interface with the ocean. However, the state variables of the pelagic BFM are expressed as concentrations in a volume of sea water. The thickness of the considered layer is taken into account in order to have every CFF of both systems (pelagic and benthic) in

the same units per cubic meters. This concept can be applied also to the coupling between BFM and BFM-SI, considering that the sea ice biology is distributed in a certain layer of sea ice (the sea ice bio, BAL of Fig. 3.3). The thickness of the layer is computed by a physical sea ice model, such as the one developed by Tedesco et al. (2010), which is a time-varying layer whose thickness depends on the physical properties of sea ice (temperature, salinity and brine volume).

### 3.6.1. Boundary fluxes: the sea ice-ocean interface

The major exchanges between the sea ice and the pelagic systems are the fluxes of organic and inorganic matter at the interface. Ice structure determines the porosity and therefore the rate of exchange: frazil ice is less porous than congelation ice and algae may experience, for instance, nutrient depletion in the former.

The rates of advection and diffusion of dissolved and particulate substances from seawater into the porous bottom layer of ice may also depend on under-ice current velocities, tides and

### 3. The sea ice biogeochemical model

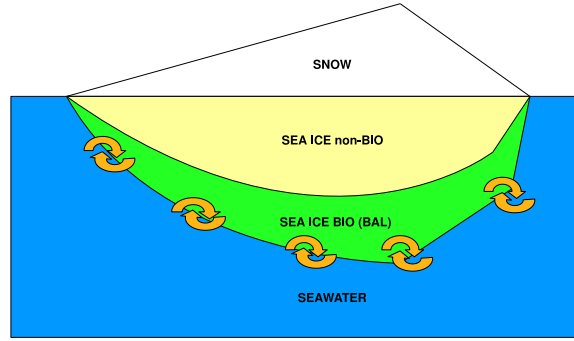

Figure 3.3.: Model representation of the sea ice and pelagic coupling during a generic ice season. The pelagic BFM exchange matter and gases with the SEA ICE BIO layer.

atmospheric pressure cycles (Cota et al., 1991). Additionally, high algal biomass in the platelet layer has been found to reduce the flux of nutrients to algae communities of the upper congelation layer in Antarctica Lizotte and Sullivan (1991).

High biomass is usually found in area of slow ice growth rate (Legendre et al., 1992). During the growth season, convection in the skeletal layer enhances nutrient fluxes (Cota et al., 1991). During the melting season, the supply of freshwater increases the stratification just below the ice and reduces the flux of nutrients upward by reducing mixing and friction velocity (Gosselin et al., 1985). Even if the enlargement and interconnections of the brine channels allows a greater biomass accumulation and nutrient supply, it also leads to an increase in the biological loss by cells sinking in the water column.

It is assumed here that the entrapment of dissolved matter follows the same partitioning of salt in sea ice, that is the dynamics of dissolved constituents is treated as the salinity dynamics, as proposed by Tedesco et al. (2009), considering the concentration of dissolved matter in seawater and sea ice growth rate. Fluxes are defined positive upward, i.e. towards sea ice in Fig. 3.2. The nitrate flux is described here as an example of an inorganic nutrient exchange. The flux is composed of a positive part (entrapment) during sea ice formation when sea ice growth is positive, and

of a negative part during the melting phase:

$$\begin{aligned} \left. \frac{dI^{(3)}}{dt} \right|_{N^{(3)}}^{flux-oce} &= \max \left( 0, \frac{\partial h_i}{\partial t} \right) \cdot \\ &\max \left( 0, N^{(3)} - \frac{I^{(3)}}{h_{bio}} \right) \\ &+ \min \left( 0, \frac{\partial h_i}{\partial t} \right) \frac{I^{(3)}}{h_{bio}} \end{aligned} \quad (3.6.1)$$

where  $N^{(3)}$  is the nitrate concentration in seawater,  $h_i$  is the ice thickness and  $h_{bio}$  is the thickness of the biologically active layer in sea ice. When ice starts melting (the last term in the equation above), the release to the water column depends only on the sea ice melting rate and on the sea ice concentration. The same flux, converted into units of volume concentration, is included with opposite sign in the dynamical equation for pelagic nutrients.

The entrapment of particulate matter is assumed to be only a function of the seawater concentration, the sea ice growth rate and the actual available space in the sea ice matrix (brine volume,  $V_{bio}$ ), while the release during the melting phase is parametrized as function of the sea ice melting rate and sea ice concentrations, as in Eq. (3.6.1). For instance, the flux of the chlorophyll component of sea ice algae  $A_l^{(1)}$ , from the pelagic variable  $P_l^{(1)}$  to sea ice is defined as:

$$\begin{aligned} \left. \frac{dA_l^{(1)}}{dt} \right|_{P^{(1)}}^{flux-oce} &= \max \left( 0, \frac{\partial h_i}{\partial t} \right) P_l^{(1)} V_{bio} \\ &+ \min \left( 0, \frac{\partial h_i}{\partial t} \right) \frac{A_l^{(1)}}{h_{bio}}. \end{aligned} \quad (3.6.2)$$

### 3.6.2. Boundary fluxes: the sea ice-atmosphere interface

Nutrient content in snow and liquid precipitation may directly lead to additional nutrient availability for surface communities, and indirectly to internal and bottom communities, and finally to surface waters once sea ice has totally melted away. In the Baltic Sea, for instance, 5% of the total annual flux of N and P and 20–40% of lead and cadmium are deposited as snow: due to the intense stratification of most of the Baltic waters, sea ice is the major source of nutrients and trace elements to the surface Baltic waters during the melting season (Granskog et al., 2006).

The physical processes responsible of the bioavailability of atmospheric nutrients to the sea ice community are snow ice formation and snow flushing. When snow ice forms the fraction of snow that mixes with flooding seawater may bring an additional source of nutrients for internal com-

munities, while during snow flushing episodes the accumulated nutrients in the melting snow may become available also for bottom communities, if brines are permeable. This latter process is the one that it is currently considered in the model for the parametrization of the flux of atmospheric nutrients to bottom sea ice, as shown in Fig. 3.2. Phosphate and nitrogen concentration in snow may be derived from an atmospheric model or may be prescribed using available observations. The flux of nutrients due to precipitation becomes then a linear function of the snow melting rate, similarly to the flux of matter from sea ice to the ocean during melting of sea ice, i.e. for nitrate:

$$\frac{dI^{(3)}}{dt} \Big|_{N^{snow}}^{flux-atm} = \min \left( 0, \frac{\partial h_s}{\partial t} \right) N^{snow} \quad (3.6.3)$$

where  $N^{snow}$  is the nitrate concentration in snow and  $h_s$  is the snow thickness.

### 3. *The sea ice biogeochemical model*

## **Part II.**

# **BFM code description**



## 4. Installation, configuration and compilation

The default basic configuration of BFM is the STANDALONE model, which simulates the biogeochemistry of a water volume with given depth. The typical example is a micro- or mesocosm batch culture. Only the pelagic system can be currently simulated with this configuration. The model is forced with prescribed or analytical functions of temperature, salinity and light and can be integrated for any desired period with three different numerical schemes. The model output is in NetCDF.

### 4.1. Installation

The BFM code repository is made available through a distributed git repository, which requires access authentication by using the username and password provided in the registration to the BFM website (<http://www.bfm-community.eu/>). The code can be downloaded using the following git instruction

```
% git clone http://username:password@dev.cmcc.it/git/bfm.git
```

Alternatively, it is possible to retrieve a tarball archive from the website. After downloading the tarball file, create a directory for the BFM and move into that directory. Uncompress and extract the contents of the tarball. The downloaded file will have a different name based on the version. For example:

```
% mkdir $HOME/BFM
% cd $HOME/BFM
% gunzip bfm-release-<version>.tgz
% tar xvf bfm-release-<version>.tar
```

This operation will create and populate the directory `bfm` containing the source files and the directory `run` for running the various test cases which are described in Sec. 5.5. The full directory tree of the BFM core is given in Fig. 4.1.

The minimal user local settings to use BFM configuration/compilation tools is provided by means of the environmental shell variable:

- `BFMDIR` The root directory of the BFM model (the path to the installed `bfm-<version>` directory).

#### 4.1.1. System Requirements

The BFM can be run on any UNIX-based architecture and it has been tested on linux, Mac OSX and IBM-iDataplex systems.

The software requirements are:

- PERL (version 5.8.2 and above), used automatically during compilation time to generate the code from the model template (see Sec. 7).

4. Installation, configuration and compilation

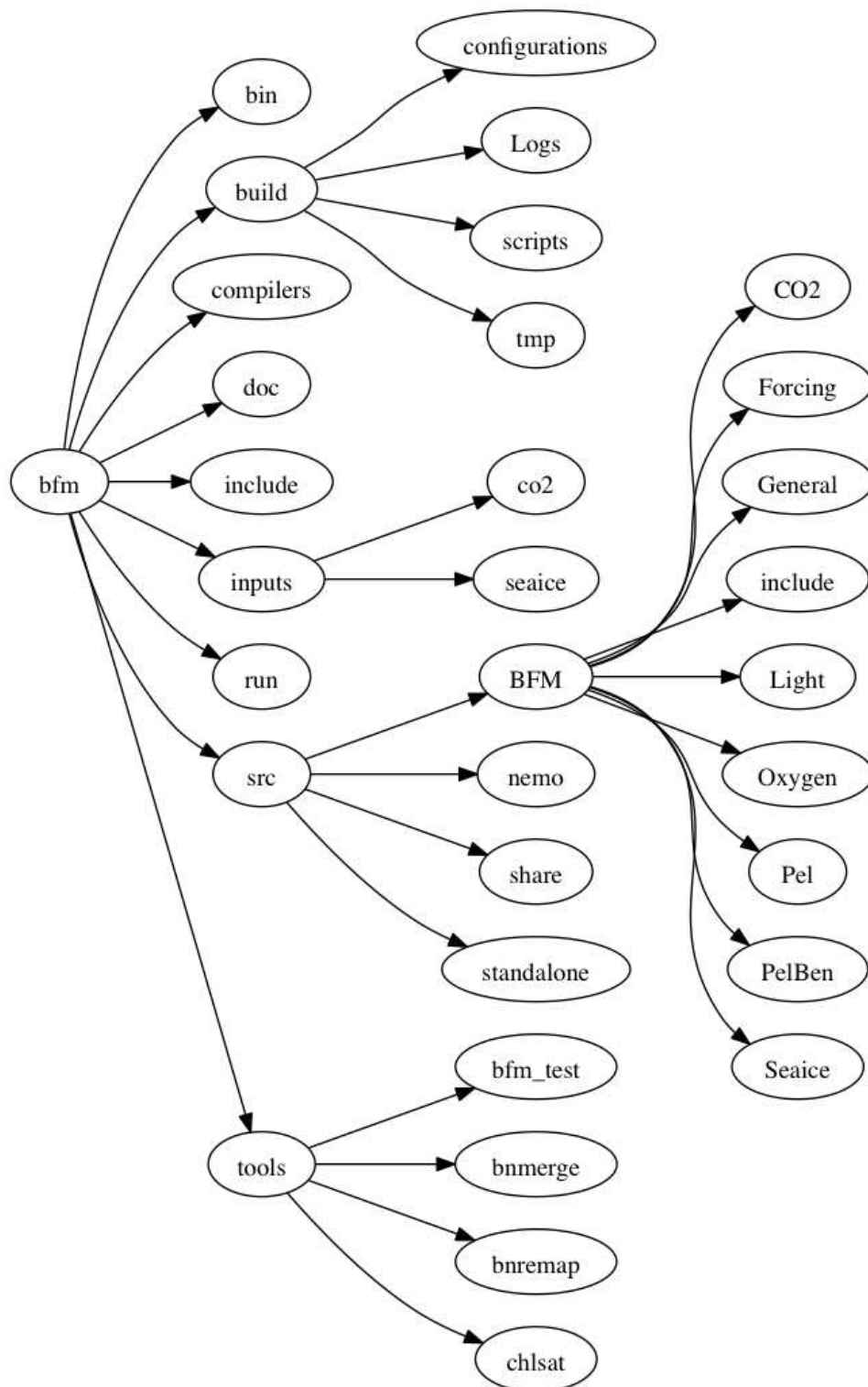

Figure 4.1.: Directory tree of the current BFM version.



- FORTRAN 90/95 compiler. Under linux and Mac OSX the model can be currently compiled with gfortran (version 4.5 and above) and ifort (version 12 and above).
- NetCDF library (version 4 and above are recommended, <http://www.unidata.ucar.edu/software/netcdf>). It is mandatory that the library has been compiled with the same compiler used for the model compilation since the F90 netcdf module is used.

## 4.2. Configuration: BFM Presets

An experiment is defined by a model layout structure, namelists, and initial input values. These definitions put together with compilation and run options is what is called a **PRESET**. A preset is contained together in a folder and it is all you need to create a particular experiment.

The basic operations for configuration, compilation, and deployment of the model are performed automatically by the script *bfm\_configure.sh* in the folder *BFMDIR/build/*, while the folder containing the presets is *BFMDIR/build/configurations/*.

Execute the following command to show a list of all available presets:

```
./bfm_configure.sh -P
```

Presets are composed of three different main files:

### - configuration (compilation and deployment options)

This file uses the F90 namelist format to set values. Below is reported an example of the configuration file format:

```
&BFM_conf
  MODE      = 'STANDALONE' ,
  CPPDEFS   = 'BFM_STANDALONE INCLUDE_PELCO2 INCLUDE_DIAG' ,
  ARCH      = 'gfortran.inc' ,
  PROC      = 1 ,
  EXP       = 'standalone.pelagic' , /
  ...
  <option>=<value>
/
```

Not all the options available in Tab. 4.1 can be specified in the configuration file and all the values are overridden by the command line options. Available options are: MODE, CPPDEFS, BFMDIR, NEMODIR, ARCH, CLEAN, PROC, NETCDF, EXP, NMLDIR, PROC and QUEUE. Do not use the character " to surround values, but use ' instead.

There are 2 major macros that belong to the core of the BFM source code and additional compilation keywords that activates model components. The first 2 macros are “negative”, which means that their options are activated by default and needs to be deactivated when desired.

Note that, the MODE field is used to specify if the code is compiled for standalone or coupled execution, thus meaning that specific settings of the script generator will be used. Beside the STANDALONE mode, additional fields will be made available following the release of the official coupling support for external hydrodynamic models.

#### 4. Installation, configuration and compilation

**BFM\_STANDALONE:** This macro controls the main memory structure of the BFM. In default configuration the BFM allocates its own memory array. When the macro is defined at compilation (`-DBFM_STANDALONE`) all the variables belonging to the main memory are defined as pointers and are not allocated during the initialization phase.

**BFM\_NOPOINTERS:** by default, all the F90 symbols of the BFM state variables are defined as pointers to the main memory (cf. Sec. 6.2). By defining this macro, it is possible to substitute all the pointers with the actual memory location. For instance, all the occurrences of the keyword `P1c(:)` which are pointers to the memory address of phytoplankton carbon content, are substituted with the name `D3STATE(ppP1c, :)`. To facilitate this feature, it is requested that all the references to the pointers in the code are written with the indication of the number of dimensions: `P1c` should always be indicated as `P1c(:)`, otherwise a pre-compiler error is generated when `BFM_NOPOINTERS` is defined. This macro is strongly recommended when BFM is coupled to hydrodynamical models.

**INCLUDE\_PELCO2:** Define and activate the pelagic variables of the carbonate system.

**INCLUDE\_PELFE:** Add iron component and activate the related dynamics in the system.

**INCLUDE\_DIAG:** Activate the computation and storage of user-defined diagnostics described in Chap. 8.

**EXPLICIT\_SINK:** Activate the explicit usage of separate source and sinks arrays (Sec. 6.2).

#### - layout (memory layout configuration file)

This file is the template to define the model components layout (Sec. 7) and user-defined diagnostics (Sec. 8.3). For a detailed description of the BFM memory layout content refer to Sec. 6.2.

#### - namelists\_bfm (namelist file with standard values)

This file contains all the standard values of the namelists<sup>1</sup> used for the experiment. Namelists are checked for consistency against the source code at generation time and the files effectively used for the simulation will be copied in the `$BFMDIR/run/<PRESETNAME>` directory.

During this phase the BFM named constants corresponding to state variables (`O2o`, `N1p`, `P1c`, ...) are substituted by the progressive number which is a function of the chosen `layout` file. This check will guarantee an executable file compatible with the namelists provided. The regular user will generally work with generated namelists and usually there is no need to change any keyword in this file besides the values in case there is the willingness to generate a new standard set of values.

After running the experiments, it is possible to modify generated namelists in the deployed experiment folder (`$BFMDIR/run/$EXP`). If you want to preserve these changes into a new "preset" you can use the tool "nmlcreator". This is for instance desired when a new group is added as in Sec. 7.2 and the parameters of the new group have to become default for the preset. To execute this tool do the following steps

```
cd $BFMDIR/build/scripts/conf
./nmlcreator.pl -i NAMELIST_IN -o NAMELIST_OUT
```

where

---

<sup>1</sup>BFM input namelists follows F90 namelist standard

### 4.3. Compiling the BFM STANDALONE

- NAMELIST\_IN: Complete path of the file containing namelist/s to read (e.g.. \$BFMDIR/run/standalone.pelagic/Pelagic\_Ecology.nml)
- NAMELIST\_OUT: Complete path of the "namelist" file of the preset where to append at the end of the input (e.g.: \$BFMDIR/build/configurations/STANDALONE\_PELAGIC\_Z/namelists).

Basically, `nmlcreator` adds the "filename\_nml\_conf" key with the name of the file at the end of each namelist read. It is important to note that it will not delete the existing namelists in the target preset, it will only append the new namelist at the end. In this case, an automatic back substitution of variables numerical indexes with the corresponding variable names (e.g. O2o, N1p) is not possible and it has to be done manually by the user if required.

## 4.3. Compiling the BFM STANDALONE

Configuration and deployment of the model is done automatically by the script `bfm_configure.sh`. After setting-up `$BFMDIR` variable in your shell environment, you can go to `$BFMDIR/build` directory and execute `bfm_configure.sh` using default preset, namely the `STANDALONE_PELAGIC`:

```
./bfm_configure.sh -gcd
```

`bfm_configure.sh` generates, compiles and/or deploys files needed for the BFM model, as specified in the preset folder. There are three different steps to have an executable model (see Fig. 4.2):

- g* (*Generation*) generate fortran files (.h , .f90) based on layout information and the single namelist files (.nml) from `namelists_bfm` in `$BFMDIR/build/tmp/<PRESETNAME>` and also place fortran files in the main code tree (`$BFMDIR/src`);
- c* (*Compilation*) compile the fortran code using files of the main code tree (`$BFMDIR/src`) and create the executable file (.x) in `$BFMDIR/bin`;
- d* (*Deployment*) create experiment folder in `$BFMDIR/run/<PRESETNAME>` and copy namelists and executable for the simulation.

At least one of these three basic instruction is mandatory.

An execution without errors<sup>2</sup> will show the output directory for running the experiment and the command to execute. Output after successful compilation should end with:

```
..... Makefile is ready.
STANDALONE_PELAGIC generation done!
Starting STANDALONE_PELAGIC compilation...
STANDALONE_PELAGIC compilation done!
Go to $BFMDIR/run/standalone.pelagic and execute command: ./bfm_standalone.x
```

Presets are loaded using option "-p" followed by the preset name, e.g.:

```
./bfm_configure.sh -gcd -p CO2TEST
```

For a full description of the script usage and available options, see Tab. 4.1 or execute the following command:

```
./bfm_configure.sh -h
```

---

<sup>2</sup>If you experience problems during the generation or compilation, visit <http://bfm-community.eu/documentation> for help

#### 4. Installation, configuration and compilation

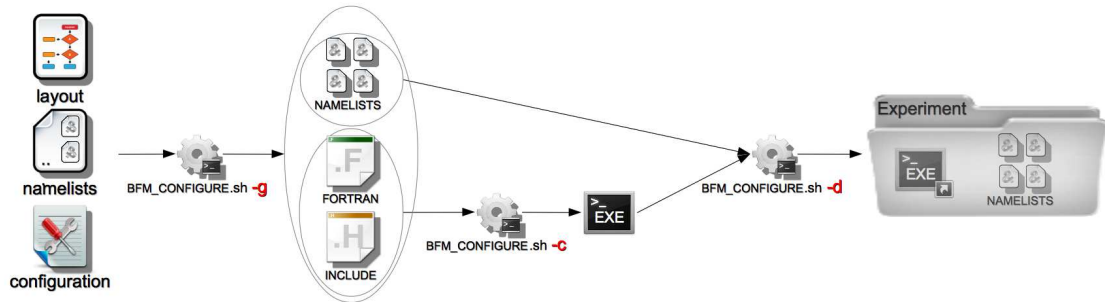

Figure 4.2.: Steps for experiment deployment

Option	Argument	Description
Compilation options		
VERBOSE	-v	Verbose mode to print all messages
PRESET	-p	Preset to generate the configuration
MODE	-m	Mode for compilation and deployment
CPPDEFS	-k	Key options to configure the model
BFMDIR	-b	path to root directory of BFM
NEMODIR	-n	path to root directory of NEMO (only for NEMO coupling)
ARCH	-a	Specify compilation Architecture file
PROC	-r	Number of procs used for compilation (and execution)
FAST	-f	Fast mode. Don't execute "clean" command in compilation
NETCDF	-t	Path to netcdf library and header files
Deployment options		
EXP	-x	Name of the experiment for generation of the output folder
NMLDIR	-l	Input dir where are the namelists to run the experiment
PROC	-r	Number of procs used for running (same as compilation)
QUEUE	-q	Name of the queue number of procs used for running

Table 4.1.: List of optional arguments for bfm\_configure

## 5. Running the STANDALONE model

### 5.1. Description

The execution of the configuration script described in the previous section creates the executable and the running environment for the default preset of the STANDALONE model (called STANDALONE\_PELAGIC). The list of the available presets is obtained with the command `bfm_configure.sh -P` and the results of the test cases are detailed in Sec. 5.5. The generated namelists are copied to the directory `$BFMDIR/run/standalone.pelagic` and the model is run by executing `./bfm_standalone.x` or `./bfm_standalone.x &> outputfile` to redirect the output messages to a file in bash.

Most of the BFM settings can be controlled via namelists. The STANDALONE model behaviour is controlled with 2 major namelist files `BFM_General.nml` and `Standalone.nml`. The first file contains the namelist to control the model setup (Tab. 5.1), model formulation (Tab. 5.2) and the initial conditions for all the functional groups declared in the preset layout file (see also 1.1). The second file control the simulation environment of the standalone model, like e.g., simulation setup (Tab. 5.4), time settings (Tab. 5.5), and environmental forcing (Tab. 5.6).

### 5.2. State variables initial conditions (IC)

The initial conditions of the model state variables are declared in the file `BFM_General.nml` within the `bfm_init_nml` namelist. As a general rule, the IC of each state variable is indicated with its code abbreviation and 0, for example Phosphate initial value will be declared as `N1p0 = 1.0`.

ICs for living and non-living components of the model (see Tab. 1.1) has to be treated as follow:

- Dissolved Inorganic (IO) components require the specification of the initial value;
- Living organic (LO) components require only the initial content of carbon (e.g., `P1c0`, `Z3c0`), while the other constituents are automatically set by the model using the optimal ratios to carbon set in the specific namelists;
- Non-living organic (NO) components require only the initial content of carbon (e.g., `R1c0`) and for those groups with more than one constituent, these are set using the Redfield ratios.

### 5.3. Numerical integration

Three integration schemes are implemented in the STANDALONE model. They can be chosen by the parameter `method` in the namelist file `standalone.nml`. They are all explicit and use a time step cutting approach to avoid negative concentrations. In detail, indicating with  $S(c_n)$  the right-hand-side source term computed with concentration  $c_n$ , they are written as:

- the Euler scheme (`method=1`):

$$c_{n+1} = c_n + S(c_n)\Delta t$$

## 5. Running the STANDALONE model

<i>name</i>	<i>kind</i>	<i>description</i>
bio_setup	integer	STANDALONE configuration: 1. pelagic 2. benthic (not yet available) 3. pelagic and benthic (not yet available)
bfm_rstctl	string	Save initial state in the output file
out_fname	string	Name of NetCDF output file
out_dir	string	Path to the output file
out_title	string	Name of the experiment in NetCDF file
out_delta	integer	Output is saved every out_delta timesteps

Table 5.1.: Parameters that control the model setup and output file (bfm\_nml in BFM\_General.nml)

<i>name</i>	<i>kind</i>	<i>description</i>
CalcPelagic	logical	Switch on off the pelagic system
CalcBenthicFlag	integer	Switch for the benthic model (only option 1. is currently allowed) 1. no benthic model; 2. simple benthic return; 3. benthic organisms and intermediate complexity nutrient regeneration; 4. benthic organisms and full nutrient regeneration (early diagenesis)
CalcPhytoplankton (P)	logical	Switch for phytoplankton (P=1,2,3,4)
CalcPelBacteria (B)	logical	Switch for pelagic bacteria (B=1)
CalcMesoZooplankton (Z)	logical	Switch for mesozooplankton (Z=1 for Z3, Z=2 for Z4)
CalcMicroZooplankton (Z)	logical	Switch for microzooplankton (Z=1 for Z5, Z=2 for Z6)
CalcPelChemistry	logical	Switch for pelagic chemistry
AssignPelBenFluxesInBFMFlag	logical	Switch to turn on/off the fluxes between the pelagic and the benthic system. Fluxes are always computed but not integrated if the flag is false
AssignAirPelFluxesInBFMFlag	logical	Switch to turn on/off the fluxes between the atmosphere and the pelagic system. Fluxes are always computed but not integrated if the flag is false
ChlDynamicsFlag	integer	Switch for chlorophyll parameterization in phytoplankton 1. constant chl:C ratio and acclimation through optimal light (ERSEM-II). Note: the variable for chl content P11 is used to store optimal irradiance in $W m^{-2}$ 2. Chlorophyll is a phytoplankton constituent and variable chl:C ratio. Note: P11 is in $mg chl m^{-3}$

Table 5.2.: Parameters that control model formulation and execution (Param\_paramteres in BFM\_General.nml)

<i>name</i>	<i>kind</i>	<i>description</i>
LightPeriodFlag	integer	Provide the light averaging period of the external irradiance: 1. Instantaneous irradiance 2. Daylight average with explicit photoperiod 3. Daily average
LightLocationFlag	integer	Choose the parameterization of light location in the discrete grid: 1. Light at the top of the cell 2. Light in the middle of the cell 3. Average Light in the cell
ChlAttenFlag	integer	Choose the PAR attenuation due to Chl: 1. broadband linear attenuation 2. 3-band tabulated attenuation coefficients

Table 5.3.: Parameters that control light properties in the water column (PAR\_paramteres in `Pelagic_Environment.nml`)

- the Runge-Kutta scheme of 2<sup>nd</sup> order (`method=2`):

$$c_{n+1} = c_n + \frac{1}{2} [S(c_n) + S(c_n + S(c_n)\Delta t)] \Delta t$$

- the leap-frog scheme (`method=3`):

$$c_{n+1} = c_{n-1} + S(c_n)2\Delta t \text{ with the Asselin-filter: } c_n = c_n + \gamma(c_{n-1} - c_n + c_{n+1})$$

## 5.4. Forcing functions

The STANDALONE model can be forced with different kind of forcing functions to provide the physical information for the aquatic system (e.g. temperature, irradiance, etc.). Two options are currently available: analytical forcing functions and data from an external file. All external data formats and time interpolations are derived from the code provided by GOTM under the GPL.

### 5.4.1. Analytical forcing functions

This option is activated by setting `forcing_method=1` in the namelist `forcings_nml` (Tab. 5.5). The simple analytical forcing functions give the user a easily accessible and quickly usable basic set-up of the physical forcing fields. The basic concept behind all forcing functions is the interpolation of some (northern hemisphere) summer and winter values by a sine wave, considering them as the two extreme values. This simple case is used for salinity forcing data (`sw` and `ss` in Table 5.6), while for temperature, in addition to the sine wave, it is possible to superimpose a daily excursion (constant all over the year).

Light forcing is interpolated with a sine wave from a winter minimum value to a summer maximum value (`lw` and `sw` in Table 5.6) to obtain the actual value of average daylight for each day of the year. These variables are as well intended as the placeholders for instantaneous light values and average daylight, i. e. the mean value of light energy over the light period:

$$\frac{1}{\text{daylength}} \int_{\tau_{dawn}}^{\tau_{dusk}} \text{light}(t) dt$$

The daylength is computed by the model as a function of the latitude value given in the namelist. In case of the instantaneous light option (`ltype=1`) the average daylight is distributed in a sine

## 5. Running the STANDALONE model

<i>name</i>	<i>kind</i>	<i>description</i>
nboxes	integer	Number of water volumes (boxes)
indepth	real	Depth of each box (m)
latitude	real	Latitude of each box
longitude	real	Longitude of each box
maxdelt	real	Maximum timestep duration (s)
mindelt	real	Minimum timestep duration (s)
method	integer	Integration method <ol style="list-style-type: none"> <li>1. Euler forward</li> <li>2. Runge-Kutta 2nd order</li> <li>3. Leap-frog</li> </ol>

Table 5.4.: Main parameters for controlling time marching and integration in the STANDALONE (standalone\_nml in Standalone.nml)

<i>name</i>	<i>kind</i>	<i>description</i>
timefmt	integer	Format of the time limits and loop: <ol style="list-style-type: none"> <li>1. MaxN only. Give number of iterations, fake start time is used.</li> <li>2. start and stop dates. MaxN calculated.</li> <li>3. start and MaxN. stop time calculated.</li> <li>4. simdays only. Give number of simulation days, fake start time used and MaxN calculated.</li> </ol>
MaxN	integer	Number of iterations in time-loop
simdays	integer	Number of simulation days
start	string	Start date
	"yyyy-mm-dd hh:mm:ss"	
stop	string	Stop date
	"yyyy-mm-dd hh:mm:ss"	

Table 5.5.: Main parameters for time management and integration length (time\_nml in Standalone.nml))



wave over the daylight period reaching thus a maximum of twice the average daylight while being zero at the beginning and in the end of the light period. In the case of constant light (`ltype=2`) the mean daylight is smoothed out over the whole day by the factor `daylength/24`. In the case of rectangular light distribution (`ltype=3`) the light equals the average daylight value over the whole daylight period and is zero at night time. In order to setup a constant-light experiment, it is sufficient to put the winter value equal to the summer value and set `ltype=2`.

### 5.4.2. Boundary forcing for atmospheric CO<sub>2</sub>

The STANDALONE model (but also any other coupled configuration that does not provide a connection with the atmosphere) has the possibility to turn on the prescription of an atmospheric CO<sub>2</sub> concentration for computing the surface fluxes. A time series can be specified as input to the atmospheric mixing ratio by setting the file name in `Carbonate_Dynamics.nml` parameters listed in Tab. 2.9. This is activated only if pelagic CO<sub>2</sub> is turned on in the model with the macros `INCLUDE_PELCO2` in the file `configuration`. The atmospheric value found in `Carbonate_Dynamics.nml` is given in units of partial pressure ( $\mu atm$ ) and not in ppm. A simple annual increase of this initial value can be turned on by giving a percentage constant rate in the variable `CO2inc` found in `Standalone.nml` (Table 5.6, set to 0 by default, if set to 1.0 gives the typical 1% annual increase).

### 5.4.3. Environmental data from file

The `forcing_method=2` option allows the user to input the environmental data directly from a file. The required input data are seawater temperature (variable `ETW`, °C), salinity (`ESW`), irradiance (in  $W m^{-2}$ , converted directly into the model variable `EIR`) and wind velocity (`EWIND`,  $m s^{-1}$ ). Any other parameter can be included by modifying the file `standalone/external_forcing.F90`. This file is a template for the input of external forcing data and must be modified by the user. The data input file format is an ASCII file with a first column indicating the date (`yyyy-mm-dd hh:mm:ss`) and one column for each parameter separated by space(s).

### 5.4.4. External event data

The model allows to input event data that force the state variables to certain values. This is useful to simulate the case of a laboratory experiment, when for instance phytoplankton is inoculated at given time interval or nutrients are restored to certain values. The syntax of the input file is the same as the environmental data file above and the template file `standalone/external_data.F90` must be modified by the user according to the state variables that have to be modified. The subroutine is implemented to overwrite any obtained value of the selected state variable(s) with the input value(s) at the prescribed time(s).

## 5.5. Test cases

### 5.5.1. STANDALONE\_CO2TEST: carbonate system model

The most simple test case is `STANDALONE_CO2TEST` that generates the run directory `run/standalone.co2test`. If the BFM is configured with `bfm_configure.sh -gcd -p CO2TEST`. It simulates a simple carbonate system equilibrium using the routines developed by OCMIP (`CalcCO2Method=2` in `Carbonate_Dynamics.nml`). Initial conditions are set for a

## 5. Running the STANDALONE model

<i>name</i>	<i>kind</i>	<i>description</i>
forcing_method	integer	Choice of the external forcing functions 1. analytical forcings 2. from file 3. interactive fluxes (not yet implemented)
ltype	integer	Light forcing options: 1. instantaneous light description 2. constant light over 24h 3. rectangular light distribution (on/off) according to photoperiod 4. Constant light averaged over the photoperiod
lw	real	Sinusoidal light intensity (boreal winter) $\text{W m}^{-2}$
ls	real	Sinusoidal light intensity (boreal summer) $\text{W m}^{-2}$
sw	real	Sinusoidal salinity (boreal winter)
ss	real	Sinusoidal salinity (boreal summer)
tw	real	Sinusoidal temperature (boreal winter) degC
ts	real	Sinusoidal temperature (boreal summer) degC
tde	real	Sinusoidal temperature daily excursion degC
ww	real	Sinusoidal wind (boreal winter) $\text{m s}^{-1}$
ws	real	Sinusoidal wind (boreal summer) $\text{m s}^{-1}$
CO2inc	real	Linear increase in $\text{CO}_2$ air partial pressure [% per year]
forcing_file	char	Filename for external forcings (forcing_method = 2)
use_external_data	logical	Read external data (user defined)
data_file	char	Filename for external data

Table 5.6.: Parameters for the external forcing functions (forcings\_nml in Standalone.nml)

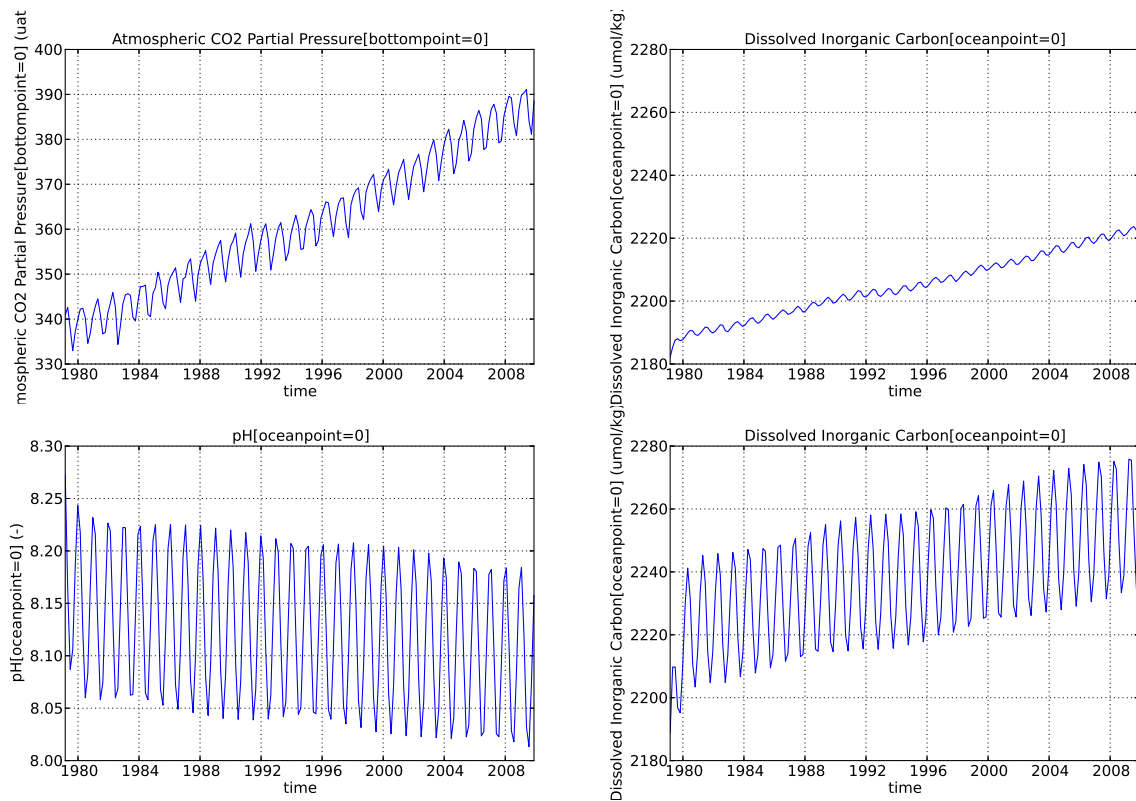

Figure 5.1.: Examples from the CO<sub>2</sub>TEST simulation. Top panels: atmospheric CO<sub>2</sub> partial pressure from the NOAA marine boundary layer data at 33N (<http://www.esrl.noaa.gov/gmd/ccgg/mbl/>) and DIC with temperature set to the constant value of 25 °C (default run). Bottom panels: pH and DIC values obtained with seasonally varying temperature ( $t_w=14$ ,  $t_s=27$  in `Standalone.nml`)

## 5. Running the STANDALONE model

Mediterranean station with high alkalinity value and output is created every 60 days. The system is forced with observed atmospheric CO<sub>2</sub> increase over the period 1979-2009. The default simulation prescribes a constant temperature value and it is interesting to note the differences shown in Fig. 5.1 when seasonal variability of temperature is turned on. The seasonal cycle in temperature can be prescribed by changing the winter and summer temperature minima and maxima of the analytical forcing functions (Sec. 5.6).

### 5.5.2. STANDALONE\_PELAGIC: the full pelagic BFM

The standard test case for the full BFM is created in directory `run/standalone.pelagic` and it is the default preset when the code is generated and compiled without any option. It simulates the seasonal cycle of a well-mixed temperate coastal sea, with mean depth 5 m. This example is to be considered as a template for other applications, as it is not meant to describe any real-world application. The simulation starts in January 2000 and terminates in 2010 with a maximum time step of 8640 s in the adaptive Runge-Kutta solver and with the output stored every 30 days (see namelists in Tab. 5.5, 5.4 and 5.1). The time evolutions of temperature, irradiance, nutrients (the system is sustained with regenerated nutrients only, therefore nitrate plot is logarithmic and goes very close to 0), chlorophyll and gross primary production are shown in Figs. 5.2-5.4 for comparison.

### 5.5.3. STANDALONE\_SEAICE: sea ice biogeochemistry

This configuration is the standard preset for the sea ice model described in Chap. 3. It describes the evolution of a sea ice season using external forcing data from a sea ice model (the data are copied from the directory `inputs/seaice` into the running directory by the configurator). The forcing functions and model output are fully described in Tedesco and Vichi (2014).

## 5.6. Output visualization

Output values are stored in netCDF according to the CF convention (<http://www.cgd.ucar.edu/cms/eaton/cf-metadata/>). The STANDALONE test cases output can be visualized with the all-round `ncview` software ([http://meteora.ucsd.edu/~pierce/ncview\\_home\\_page.html](http://meteora.ucsd.edu/~pierce/ncview_home_page.html)), with the Python utility `PyNcview` <https://sourceforge.net/projects/pyncview/> or with `ncbrowse`. Matlab users can use the `bfm_ncload.m` utility available in the `tools` directory. The figures presented in Sec. 5.5 have been produced with `pyncview`.

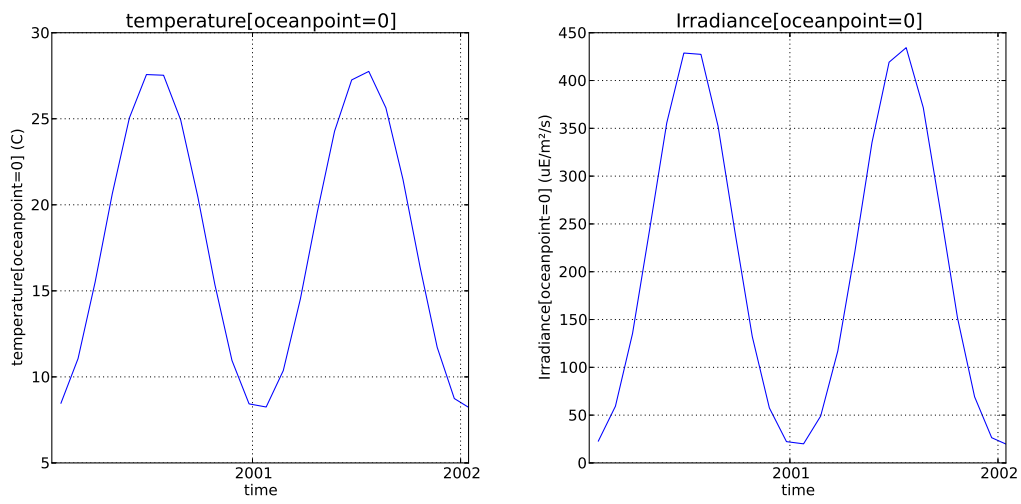

Figure 5.2.: Sample output of the STANDALONE\_PELAGIC test case: temperature (left) and irradiance (right)

5. Running the STANDALONE model

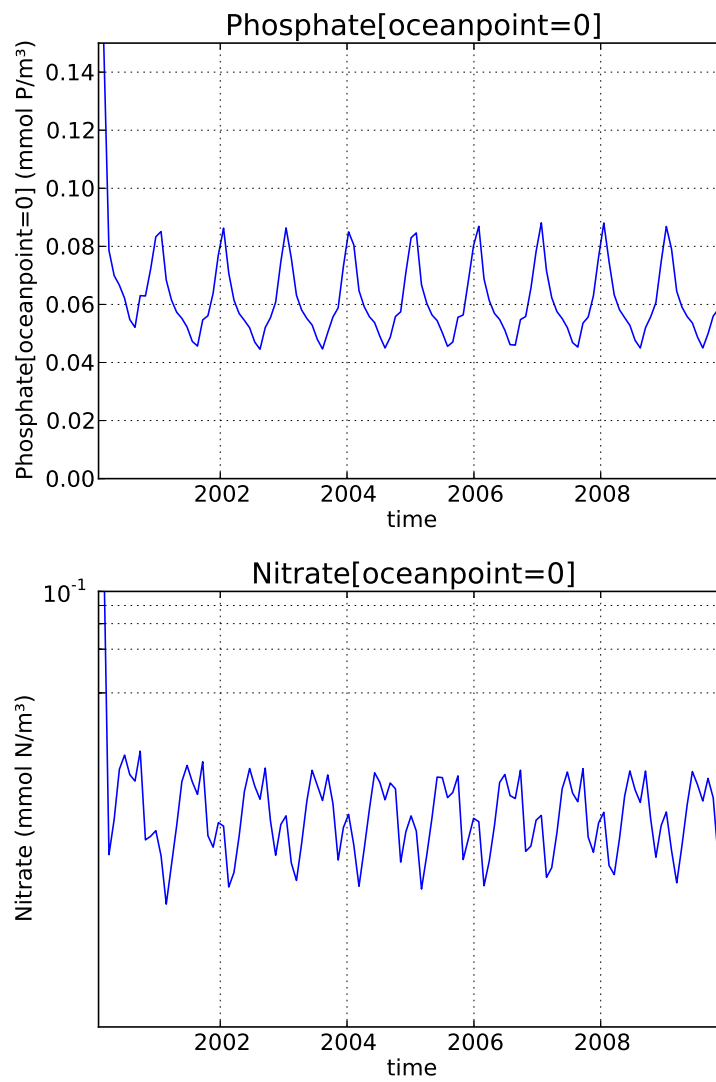

Figure 5.3.: Sample output of the STANDALONE\_PELAGIC test case: phosphate (top) and nitrate (bottom)

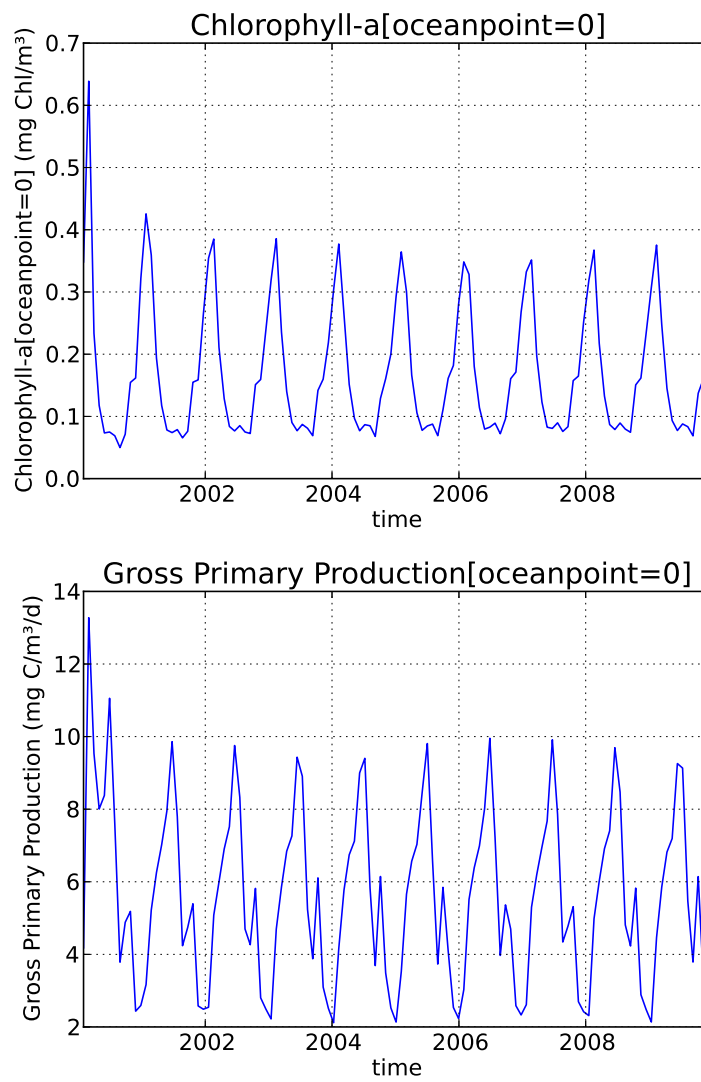

Figure 5.4.: Sample output of the STANDALONE\_PELAGIC test case: Chlorophyll-a (top) and gross primary production (bottom)

## 5. *Running the STANDALONE model*



## 6. Structure of the code

### 6.1. Coding rules

The BFM is written in plain F90 and it can generally be compiled with any F90 (and above) compiler. There are no fixed coding rules apart from standard clean programming. For historical reasons, the subroutine and symbols of the BFM biogeochemistry module are indicated with C-style capitalized long-names (e.g. EcologyDynamics), even if F90 does not distinguish capital letters. Constants and main memory arrays are generally indicated with capital names, to highlight their global static behavior. It is recommended to follow this style when possible.

### 6.2. Memory layout and variable definition

The BFM is structured similarly as the original ERSEM used to be. Pelagic variables are defined as virtually 3-dimensional, while benthic and sea ice variables are 2-dimensional. Only the sea-points are stored in memory, and thus the BFM has no knowledge of any land-sea mask or spatial relationships between grid-points in general. The number of bottom points is the same as the number of surface points, therefore the 2-D arrays can also be used for the surface variables and/or surface fluxes. These definitions are also maintained when the model is applied to a 1-D vertical setup. In that case, the pelagic variables have the spatial dimension of the number of vertical layers while the benthic and surface variables have dimension 1 (the bottom and surface levels, with the index depending on the definitions of the physical model). In a 0-D setup (as in the STANDALONE test cases described in Chap. 5), the same grid-point is at the same time a bottom, surface and ocean layer.

Fig. 6.1 illustrates the memory layout of pelagic variables. They are gathered in a single 2-dimensional array holding the number of different variables and the number of ocean grid-points:

```
D3STATE(NO_D3_BOX_STATES,NO_BOXES)
```

and the same is done for the 2-dimensional variables (defined for the benthic and sea ice ecosystem models):

```
D2STATE(NO_D2_BOX_STATES,NO_BOXES_XY)
```

Each variable memory is accessed by means of a pointer to the corresponding row containing all the grid-point values. This pointer array has the same naming convention of ERSEM. The rows are numbered with named constants starting with the letters `pp` (`ppP1c` for phytoplankton carbon, `ppN1n` for nitrate or `ppR1p` for dissolved organic phosphorus, etc.). When the BFM is coupled to a 3-D model, then a mapping function must be taken into account as shown in Fig. 6.1 in order to compute the transport terms.

In addition to this direct mechanism, the memory can be accessed by means of *group functions*. These functions have been created to allow the addition of any number of sub-groups in the same trophic compartment, such as diatoms, nanoflagellates, picoplankton, etc. in the group of phytoplankton. The group function is in this case called `PhytoPlankton(no_of_subgroups, no_of_components)`, and allows to access the memory `P1c` by writing

## 6. Structure of the code

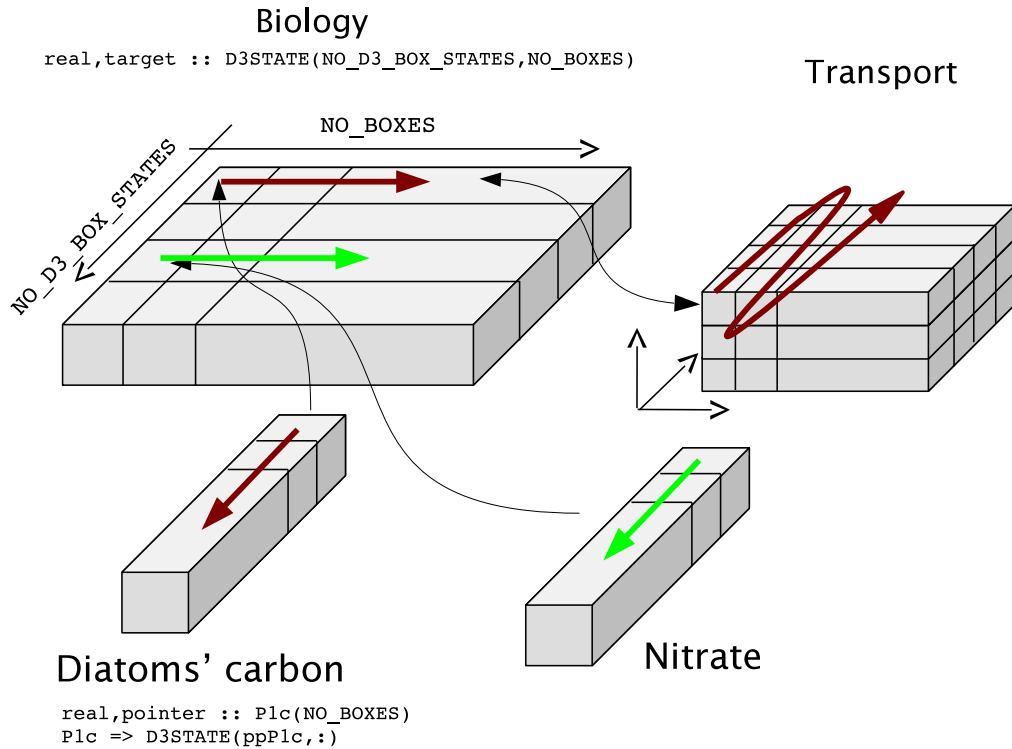

Figure 6.1.: Layout of the main memory array for the pelagic variables (D3STATE) and schematic of the remapping into a three-dimensional ocean grid for transport processes.

```
PhytoPlankton(iiP1,iiC)
```

The model state variables and components are defined in the model layout file of each preset (Sec. 4.2) which will be detailed in Chap. 7. It is now only sufficient to list the constants indicating the constituents, namely `iiC`, `iiN`, `iiP` and `iiSi`. For each defined group there is a named constant starting with the letters `ii` which holds the total number of existing subgroups (e.g. `iiPhytoPlankton`).

A typical example of the use of groups is to compute the total amount of food available to microzooplankton (from `MicroZoo.F90`):

```
do i = 1 ,iiPhytoPlankton
  PPYc(:,i) = p_paPPY(zoo,i)*PhytoPlankton(i,iiC) * &
             MM_vector(PhytoPlankton(i,iiC), p_minfood(zoo))
  rumc = rumc + PPYc(:,i)
  rumn = rumn + PPYc(:,i)*qncPPY(i,:)
  rump = rump + PPYc(:,i)*qpcPPY(i,:)
end do
```

Compare this code with the equation for food availability and capture efficiency presented in Sec. 2.4.1 of the BFM description and it will show how it is simple to cycle over all the phytoplankton variables, independently of the number and type of the defined subgroups.

The other basic arrays of the memory are the ones containing the time rates of change due to each physiological or ecological interaction. The rate of mass exchange between two state variables is an

element of an array `D3SOURCE`, if it is a production term, and `D3SINK` if it is a loss term, both with dimensions `NO_D3_BOX_STATES × NO_D3_BOX_STATES × NO_BOXES` (Fig. 6.2). It is clear that the two matrices are symmetrical and a predation (negative) rate from variable `P1c` to `Z4c` is equivalent to an ingestion rate (positive) of `Z4c` over `P1c`. All the rates are defined positive by convention, so that to obtain the net rate of change for variable of row `j`, it is sufficient to compute

$$\text{sum}(\text{D3SOURCE}(j, :, :) - \text{D3SINK}(j, :, :))$$

Fluxes which involve a variable not defined in the model, such as oxygen production from water during photosynthesis can be taken into account by using the diagonal of the matrix. There is a positive flow from `O2o` to itself computed stoichiometrically from the gross carbon production rate and inserted in `(D3SOURCE(O2o, O2o, :))`, cf. Fig. 6.2).

The same definitions apply for the 2-dimensional system, and the arrays are called `D2SOURCE` and `D2SINK` with dimensions `NO_D2_BOX_STATES × NO_D2_BOX_STATES × NO_BOXES_XY`.

This separation between positive and negative terms allow to use more sophisticated positive-definite integration schemes, but it may result in an excessive memory usage. Thus, the default setting of BFM make use of a shrank version of `D3SOURCE(NO_D3_BOX_STATES × NO_BOXES)`, which is the result of the addition of all the terms after the combination of the two symmetrical matrices into one that contains all the source (upper-left part) and sink (lower-right part) terms. It is possible to use the two separated matrices for source and sinks terms through the inclusion of the compilation macro `EXPLICIT_SINK` in the preset configuration file.

No direct mass exchanges are allowed between variables from different realms (like for instance between pelagic and benthic variables), and therefore those fluxes are defined as diagonal fluxes each one within its own realm taking into account any change of units. Specialized functions have been written to take into account all the possible kind of exchanges and are collected in `General/FluxFunctions.F90`.

## 6.3. The BFM flow-chart

The BFM core will be described in its `STANDALONE` configuration. The main program (Fig. 6.3) consists of 3 subroutines, one for initialization, one for the time-loop and one for closing all active processes. The same structure is likely to be maintained also for all the coupled configurations, but the calls are going to be distributed differently according to the structure of the general circulation model.

### 6.3.1. Initialization procedures

The initialization of the BFM requires 4 different phases:

1. Initialization of geometric domain (number of boxes/gridpoints). This part depends on the configuration: in the `STANDALONE` case, this is done in `standalone/standalone.F90[init_standalone]` while in the other coupled configuration there are specific interface subroutines;
2. Initialization of the set-up via namelist and definition of variable information (`share/api_bfm.F90[init_bfm]` for the `STANDALONE` case);
3. Definition of variable information and allocation/initialization of variables;
4. Initialization of the NetCDF output.

## 6. Structure of the code

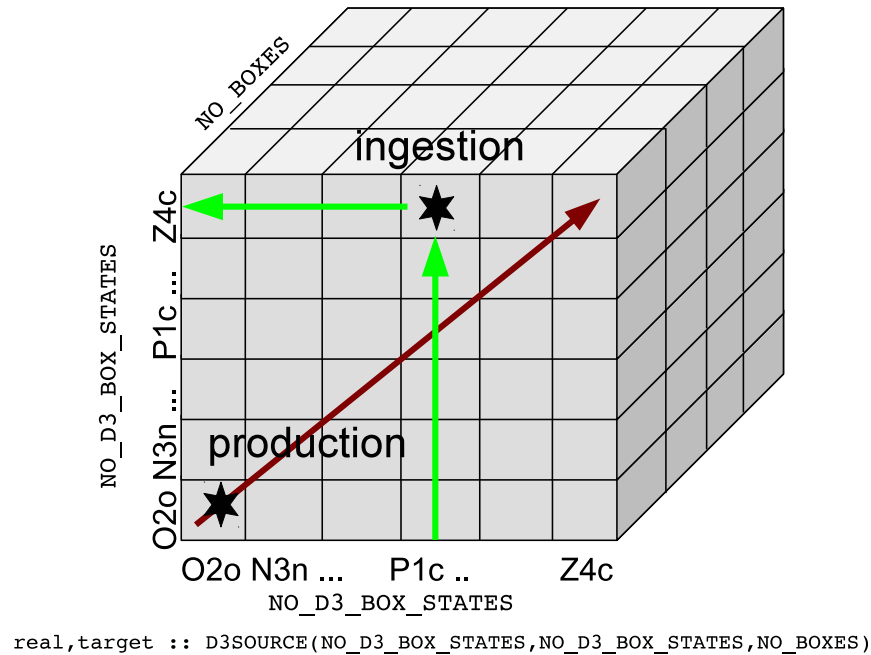

Figure 6.2.: Schematic of the D3SOURCE array collecting the source terms.

### 6.3.2. Time marching

The time marching is driven by the host hydrodynamical model, or in the case of the STANDALONE model, by a specific built-in routine. The phases of the time stepping shown in Fig. 6.3 are the following:

1. update of the physical forcing functions needed by the biogeochemical model (temperature, irradiance, wind, etc.). This is done by subroutine `envforcing_bfm`, which in the case of the STANDALONE model computes the analytical values based on the time of the day/year. When coupled with an ocean model, this routine is the contact point between the two models. Note that information may flow in two directions because the light attenuation coefficient might also be passed back to the physical model via this routine.
2. computation of the reaction term for the BFM module. This is done in `EcologyDynamics`, which is further explained in the next section.
3. numerical integration of the biogeochemical terms. In the Standalone model there are three different numerical schemes that can be used (see Sec. 5.3). Note that `EcologyDynamics` can be called more than one time by this routine when the integration scheme is of higher-order.
4. preparation and writing of the NetCDF output, routines `calcmean_bfm` and `save_bfm` (the names of the routines can be different for each coupling according to the ocean model structure and naming conventions).

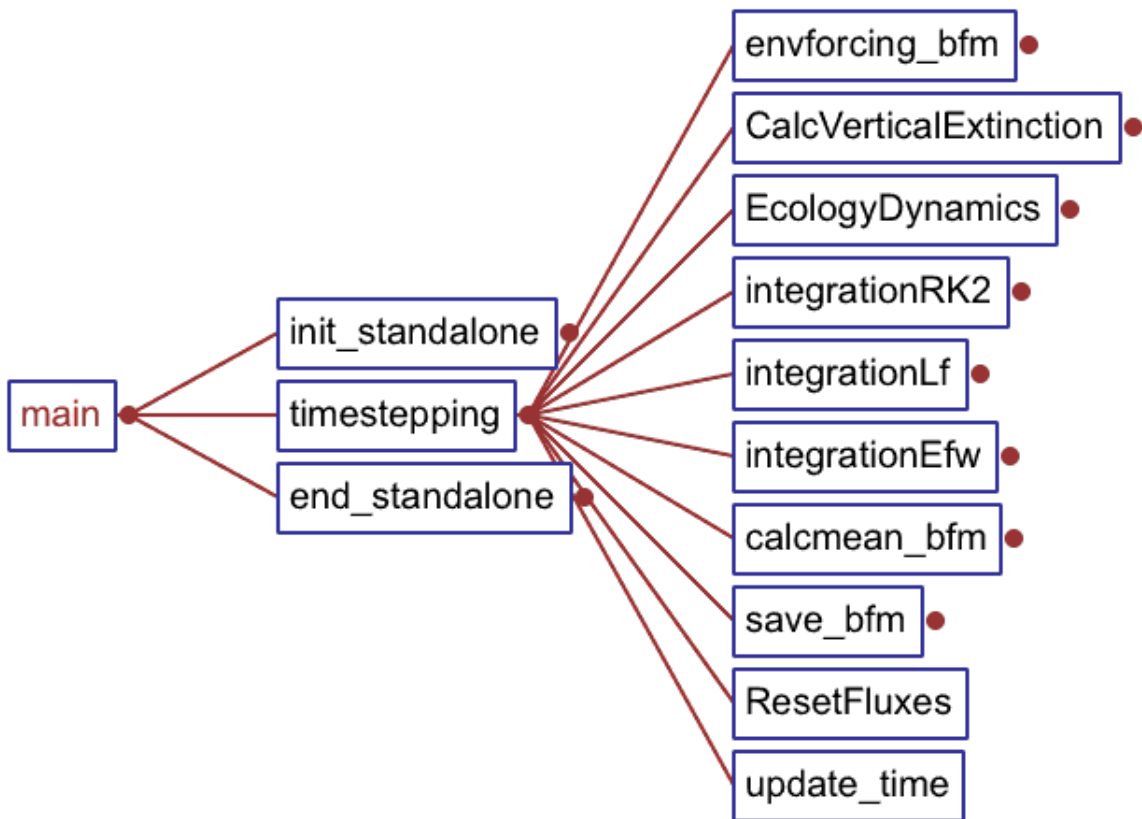

Figure 6.3.: Invocation tree of the Standalone main.

6. Structure of the code

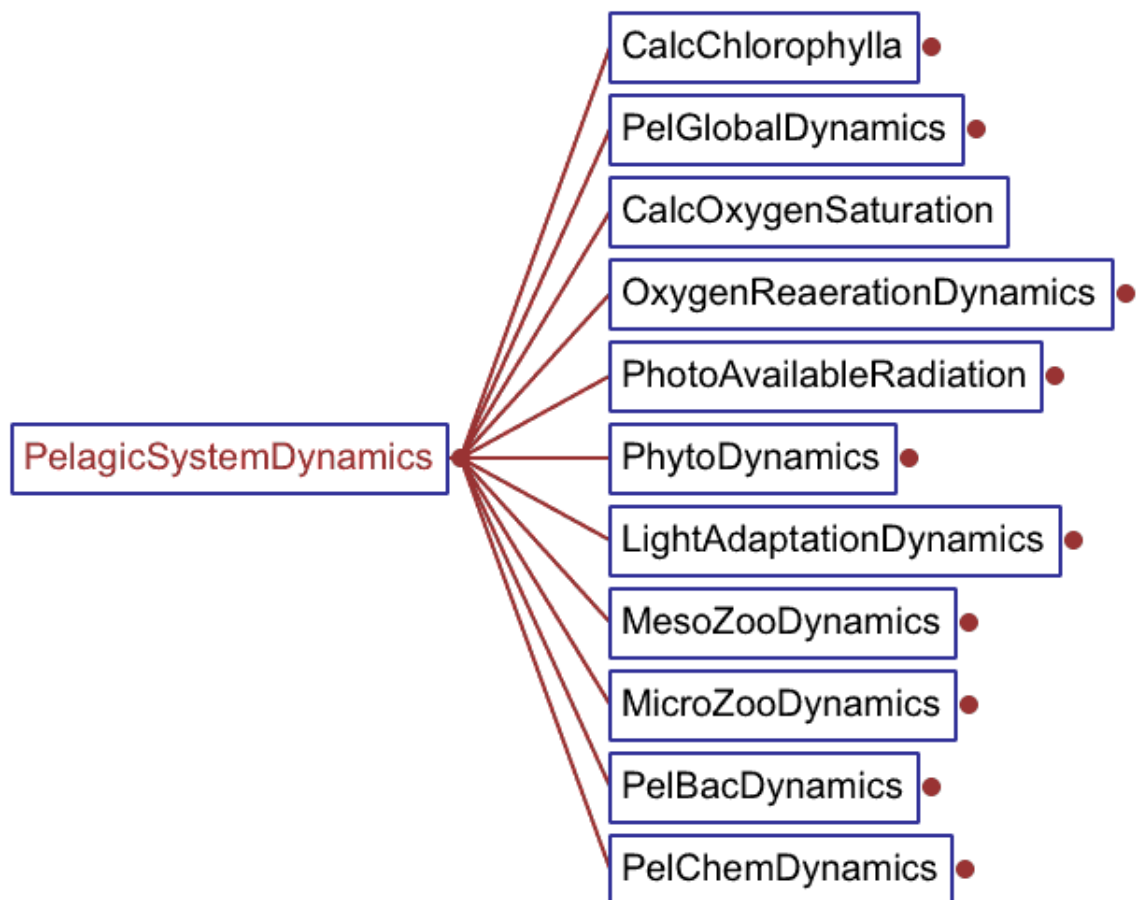

Figure 6.4.: Invocation tree for `PelagicSystemDynamics`

### 6.3.3. Computation of pelagic reaction terms

The pelagic components are computed in `PelagicSystemDynamics`, which invokes the routines shown in Fig. 6.4. It first sets the diagnostic values for total chlorophyll (sum of all the chlorophyll components in phytoplankton) and for the nutrient:carbon ratios in all the components (`PelGlobalDynamics`) and for oxygen saturation and surface fluxes with the atmosphere.

The routines for the computation of light availability are only used when the parameterization of optimal irradiance is activated (as in ERSEM-II, Ebenhöf et al., 1997), see Sec. 2.2.7, which is done in `Param_parameters` (Tab. 5.2) by setting `ChlDynamicsFlag=1`.

The standard groups, phytoplankton, meso- and micro-zooplankton and bacteria are computed in `PhytoDynamics`, `Meso- MicroZooDynamics` and `PelBacDynamics`, respectively. The same routine is modularly used for each sub-group, as

```

!-----
! Compute phytoplankton dynamics
!-----
do i =1,iiPhytoPlankton
  if ( CalcPhytoPlankton(i) ) call PhytoDynamics( i )
end do

...

!-----
! Compute MesoZooPlankton dynamics
!-----
do i =1,iiMesoZooPlankton
  if ( CalcMesoZooPlankton(i) ) call MesoZooDynamics( i )
end do

```

`PhytoDynamics` has the declaration structure depicted in Fig. 6.5. This is an example of how the memory layout presented in Sec. 6.2 is accessed by each submodel of the BFM. To refer to the pointer of each phytoplankton component, one can use the placeholder function `ppPhytoPlankton(i, j)`, where  $i$  is the phytoplankton subgroup number (up to 4 in the reference model) and  $j$  is the component (c, n, p, etc). Using `ppPhytoPlankton(1, iiC)` is equivalent to writing `ppP1c`.

The function `flux_vector` is invoked many times by `PhytoDynamics` (Fig. 6.5) because it is used to fill in the source/sink term arrays described in Sec. 6.2. This function is used throughout the BFM modules. In case of a mass exchange term such as the excretion of dissolved carbon we have

```
call flux_vector(iiPel,ppphytoc,ppR1c,rr1c)
```

where the flux is pelagic (`iiPel`), from phytoplankton carbon to dissolved organic carbon (`ppphytoc`, `ppR1c`) and the value is `rr1c`, which will be assigned both to `D3SINK` and `D3SOURCE` in the appropriate element. The oxygen production rate is instead assigned as

```
call flux_vector(iiPel,ppO2o,ppO2o,rugc/MW_C)
```

which concerns a pelagic flux (`iiPel`), on the oxygen diagonal (from `ppO2o` to `ppO2o`) and `MW_C` is the mass weight of carbon to convert gross primary production (`rugc`). Since the last term is positive, this flux will be assigned to `D3SOURCE`.

The same methodology is applied for all the other pelagic fluxes and also in the benthic and sea ice system. After the computation of all the reaction terms for pelagic organisms, there is the call

## 6. Structure of the code

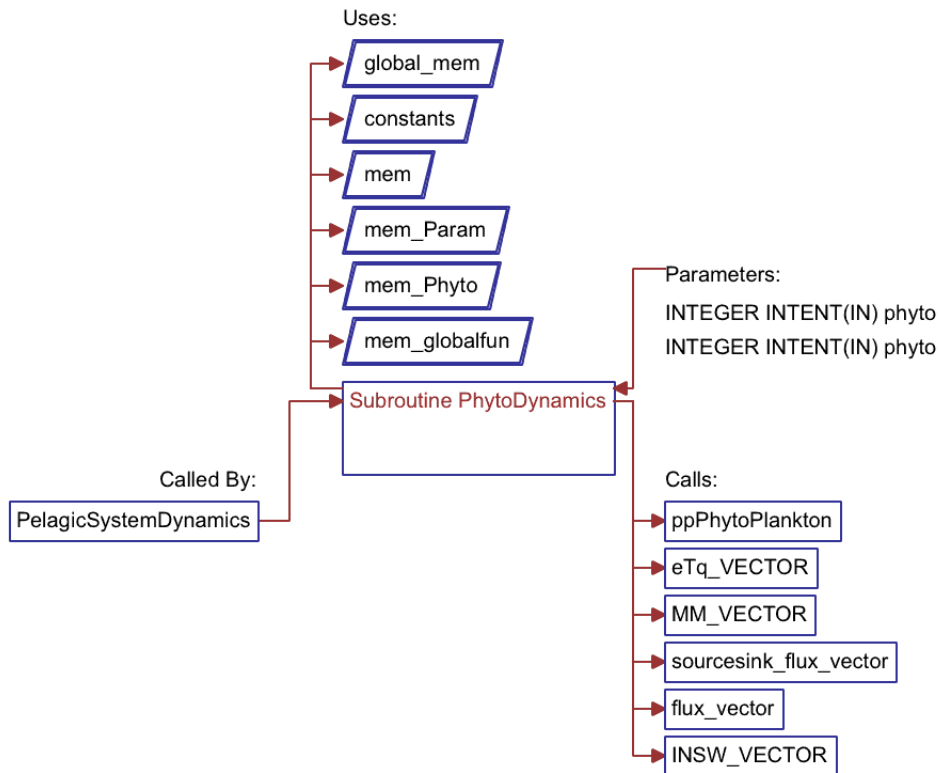

Figure 6.5.: Declaration scheme of `PhytoDynamics`.

to pelagic chemistry (`PelChemDynamics`, see Fig. 6.4). This part computes all the parameterized bacteria-mediated biochemical processes such as nitrification and denitrification, re-oxidation of reduction equivalents and dissolution of biogenic silica.



# 7. Design model layout components

## 7.1. Layout syntax and modular structure

The BFM is conceived in a modular way and the number of state variables and biogeochemical basic components can be modified according to the modelling needs. In fact, each state variable is not defined directly in the code, but through a model template layout found in the PRESET directories (Sec. 4.2, `$BFMDIR/build/configurations`). All the ancillary F90 memory layout files (`AllocateMem.F90`, `INCLUDE.h`, `ModuleMem.f90`, `set_var_info_bfm.f90`) are automatically generated from this meta-data structure by way of a perl script (`$BFMDIR/build/script`). The prototypes of these files are found in directory `$BFMDIR/BFM/proto` and filled in with the user-defined state variables and diagnostics.

The structure of the model template given in Tab. 7.1 is divided in sections with specific headings. Sections can be repeated many times in the file. For clarity, it is suggested to follow a conceptual construction of the model, by grouping all the state variables and diagnostics as done in the standard released structure.

**3d-state:** this section is used for all the state variables, which are defined as being virtually three-dimensional. This means that they exist in the whole domain, be it 0-, 1- or 3-dimensional. An example of state variable definition is shown in Box 7.1.

According to the theoretical model description, variables are defined as functional families and identified by their main biochemical components, which are indicated according to the classical ERSEM syntax (Blackford and Radford, 1995). State variable definitions require 3 pieces of information, separated by colons: code symbol with components, long name and units. Components are indicated by one single letter and currently the following are reserved: c=carbon, n=nitrogen, p=phosphorus, s=silica, l=chlorophyll, f=iron. Any other new component (either atomic or molecular) can be added, provided that the user include the relative dynamics in an appropriate piece of code. The syntax for a multi-component variable is detailed below `varname[cnp...]`, and it is also possible to define group of state variables, such as `PhytoPlankton` or `PelDetritus` as shown in Box 7.1. This feature gives the advantage to cycle over all the group components with one single index (see the example in Sec. 6.2).

**2d-state:** all the features described above are also valid for the state variables belonging to the benthic or sea ice 2-D system.

**1d-variable:** this section defines the variable without a spatial component (more appropriately defined as 0-D variables). These are only function of time and defined as scalars.

**2d-variable:** this section includes the surface variables, originally identified as benthic variables. However, this section is also used to define surface variables such as wind velocity. In a 1D coupled model, this is a scalar, while it is a one-dimensional array holding all the surface (bottom) points in a coupled 3D model.

## 7. Design model layout components

```
...  
  
#-----  
#           PELAGIC STATE VARIABLES (volume)  
#-----  
3d-state  
  
#-----  
#           State Variable(s) for Nutrients  
#-----  
N1p  :           Phosphate : mmol P/m3  
N3n  :           Nitrate   : mmol N/m3  
N4n  :           Ammonium  : mmol N/m3  
  
#-----  
#           State Variable(s) for Phytoplankton  
#-----  
group PhytoPlankton[cnpls] (PPY) : mg C/m3 : mmol N/m3 : mmol P/m3 :  
                                   mg Chl/m3 : mmol Si/m3  
    P1           : Diatoms  
    P2[-s]       : Flagellates  
    P3[-s]       : PicoPhytoplankton  
    P4[-s]       : Large Phytoplankton  
end  
  
#-----  
#           State Variable(s) for Mesozooplankton  
#-----  
group MesoZooPlankton[cnp] (MEZ) : mg C/m3 : mmol N/m3 : mmol P/m3  
    Z3           : Carnivorous Mesozooplankton  
    Z4           : Omnivorous Mesozooplankton  
end  
  
end
```

Table 7.1.: Example of the model template file layout with the definition of pelagic state variables.

**3d-variable:** this section is used for all the ancillary diagnostic variables defined in the whole domain. Typically, this section is used for temperature, salinity, and other environmental or diagnostic variables. Environmental variables obtained from external data files or hydrodynamical models are indicated with capital symbols starting with E (e.g. ETW = environmental temperature of water).

The syntax of the allowed layout elements is the following

```
[dim]d-state [-if-exist]
      GROUP
      VARNAME
end

[dim]d-variable [-if-exist]
      VARNAME
      ARRAYNAME
      QUOTUM
end

[dim]d-flux [-if-exist]
      FLUXNAME
end
```

- **GROUP**, like PhytoPlankton

```
group name[constituents] (acronym) : constituent_units
      VARNAME
end
```

- **VARNAME**, like N1p or P2 [-s] (if present, the constituent within brackets are removed from the group list of elements)

```
name[-constituents] : description : units
```

- **ARRAYNAME**, a variable that is defined for each element of a group, like the specific uptake for each phytoplankton suPPY (PhytoPlankton)

```
name(groupname) : description : units
```

- **QUOTUM**, like qncPPY (PhytoPlankton) (quotum N:C for each phytoplankton group)

```
q+constituent+constituent+acronym() : description : units
```

- **FLUXNAME**, the named entity for a user-defined flux like ruPPYc (Sec. 8.3)

```
name = FLUX : description : units
```

- **FLUX**, an expression combining several variables to store fluxes between components (Sec. 8.3)

```
(var[+|-]var) [<-|->] (var[+|-]var)
```

with the following fundamental elements

## 7. Design model layout components

- **name**: an alphanumeric string starting with a non-numeric character
- **constituents**: one or several from the list: *c* (Carbon), *n* (nitrogen), *p* (phosphorus), *s* (silicon), *f* (iron), *l* (chlorophyll). They have to be written in lower case and without any separation
- **description**: phrase describing the variable, quota or flux
- **units**: units in which the variable, quota or flux are measured
- **constituents\_units**: units separated by “:”. Have to be same number of units as constituents have been specified
- **groupname**: name of a group, also name of the function to access the group components
- **var**: variable name (e.g. *R6c*) or first letter of group with constituents for naming all (e.g. *P.c*)
- **acronym**: acronym representing the group. Currently accepted acronyms are: *PPY* (PhytoPlankton), *PBA* (PelBacteria), *MEZ* (MesoZooPlankton), *MIZ* (MicroZooPlankton), *OMT* (PelDetritus), *CAR* (Inorganic)
- **dim**: dimension of the layout elements inside. Allowed values are: 1, 2 and 3

The configuration can be also modified at compilation time by means of the set of macros listed in Sec. 4.2. The statement `-if-exist` found after one of the layout declarations indicates that the following set of variables will be defined only when the macro is included in the compilation:

```
3d-variable -if-exist INCLUDE_PELCO2
  DIC      : Dissolved Inorganic Carbon : umol/kg
  CO2      : CO2(aq) : umol/kg
  pCO2     : Oceanic pCO2 : uatm
  HCO3     : Bicarbonate : umol/kg
  CO3      : Carbonate : umol/kg
  Ac       : Alkalinity : umol eq/kg
  pH       : pH : -
end
```

### 7.2. Example 1. Adding a subgroup

This is the most simple example, because it involves a small number of changes. Let us assume we want to add another mesozooplankton component to the zooplankton group, such as macrozooplankton (as done for instance by Berline et al., 2011). It is also assumed that this group will have exactly the same dynamics as the other two subgroups, but different parameter values. It is first suggested to create a new preset by copying the directory `STANDALONE_PELAGIC` to a new name

```
cd $BFMDIR/build/configurations
cp -r STANDALONE_PELAGIC STANDALONE_PELAGIC_Z
```

and then edit the appropriate line in the template file `layout` by adding the new variable name and long name:

## 7.2. Example 1. Adding a subgroup

```
#-----
#      State Variable(s) for Mesozooplankton
#-----
      group MesoZooPlankton[cnp] (MEZ) : mg C/m3 : mmol N/m3 : mmol P/m3
              Z3      : Carnivorous Mesozooplankton
              Z4      : Omnivorous Mesozooplankton
              Z2      : Macrozooplankton

      end
```

It is also suggested to edit the name of the run directory where the namelists will be copied. This is done in the configuration file \$BFMDIR/build/configurations/configuration and change

```
EXP      = 'standalone.macrozoo'
```

Now the configuration can be generated by compiling the new preset

```
cd $BFMDIR/build
./bfm_configure.sh -gcd -p STANDALONE_PELAGIC_Z
```

and the script will take care of the automatic generation of the new memory layout with the required named constants, pointers, initial value, run directory and namelists. A new Z2 element will be added to the group MesoZooPlankton (in this case Z2 will be the third element as it comes after Z3 and Z4). Particularly, a new column will be added in the mesozooplankton namelist and filled in with zero. A warning is issued for each added column or row of parameters:

```
WARNING: (2 < 3) adding zero values to element p_q10 in namelist MesoZoo
WARNING: (2 < 3) adding zero values to element p_srs in namelist MesoZoo
WARNING: (2 < 3) adding zero values to element p_sum in namelist MesoZoo
...
WARNING: (2 < 3) adding new predator term p_paMIZ(3,:) in namelist MesoZoo
WARNING: (2 < 3) adding new predator term p_paPPY(3,:) in namelist MesoZoo
```

Check the updated file tmp/STANDALONE\_PELAGIC\_Z/ModuleMem.F90 and search for the new variable Z2 to see the added pieces of code.

The final steps before running the new model are the addition of the proper parameter values in place of zeros in the new column/rows corresponding to Z2 of MesoZoo\_parameters in run/STANDALONE\_PELAGIC\_Z/Pelagic\_Ecology.nml

```
&MesoZoo_parameters
!
      Z3      Z4      Z2
      p_q10   = 2.0    2.0    0.0
      p_srs   = 0.01   0.02   0.0
      p_sum   = 2.0    2.0    0.0
      p_vum   = 0.025  0.025  0.0
      p_puI   = 0.6    0.6    0.0
      p_peI   = 0.3    0.35   0.0
      p_sdo   = 0.01   0.01   0.0
      p_sd    = 0.02   0.02   0.0
      p_sds   = 2.0    2.0    0.0
      p_qpcMEZ = 1.67d-3 1.67d-3 0.0
      p_qncMEZ = 0.015  0.015  0.0
      p_clO2o = 30.0   30.0   0.0
!
      P1      P2      P3      P4
!  Z3
      p_paPPY(1,:) = 0.0    0.0    0.0  0.0
```

## 7. Design model layout components

```

!   Z4
!   p_paPPY(2, :)      =  1.0      0.0      0.0  0.7
!                       Z5        Z6
!   Z3
!   p_paMIZ(1, :)     =  0.0      0.0
!   Z4
!   p_paMIZ(2, :)     =  1.0      0.0
!                       Z3        Z4        Z2
!   Z3
!   p_paMEZ(1, :)     =  1.0      1.0      0.0
!   Z4
!   p_paMEZ(2, :)     =  0.0      1.0      0.0
!                       Z5        Z6
!   Z2
!   p_paMIZ(3, :)     =  0.0      0.0
!                       P1        P2        P3    P4
!   Z2
!   p_paPPY(3, :)     =  0.0      0.0      0.0  0.0
!                       Z3        Z4        Z2
!   Z2
!   p_paMEZ(3, :)     =  0.0      0.0      0.0
/

```

and to turn on the flag `CalcMesoZooPlankton(3)=.TRUE.` in `Param_parameters` and add initial value(s) by adding a line `Z2c0=<value>` in `bfm_init_nml`, both found in file `run/STANDALONE_PELAGIC_Z/BFM_General.nml`.

### 7.3. Example 2. Adding a biochemical component and a group

The BFM application in the global ocean is called PELAGOS (PELAGic biogeochemistry for Global Ocean Simulations) and the climatological simulations were described in Vichi et al. (2007a). A major requirement to simulate the global ocean ecosystem is the introduction of iron control on phytoplankton growth (Sec. 2.2.8), particularly to capture the high-nutrient low-chlorophyll regions. The example below shows how the iron component of phytoplankton and detritus have been added to the model structure template. Additional coding from the user is then required to parameterize the fluxes between these components and the regulations of plankton physiology (this is already included in the `GYRE_BFM` preset that requires the usage of the NEMO model and activated with the keyword `INCLUDE_PELFE`).

To add an iron constituent to a group, it is sufficient to specify a unique single-character constant between the square brackets in the `layout` file as shown below:

```

#-----
#   State Variable(s) for Phytoplankton
#-----
group PhytoPlankton[cnplsf] (PPY) : mg C/m3 : mmol N/m3 : mmol P/m3 :
                                mg Chl/m3 : mmol Si/m3 : umol Fe/m3
    P1      : Diatoms
    P2[-s]  : Flagellates
    P3[-s]  : PicoPhytoPlankton
end

```

#### 7.4. Example 3. Removing components from zooplankton

It is also necessary to provide units separated by colons, in this case  $\mu\text{mol Fe m}^{-3}$ . Remember that the [-s] syntax in some phytoplankton groups indicates that this constituent, although being a component of the group vector, is not computed for that specific sub-group.

The preprocessing script will take care during compilation to generate an adequate entry in the main memory module and the definitions of the named constants (ppP1f, ...) and pointers (P1f, ...) to access the new variables from the model code.

New groups can also be defined in order to use the facilities shown in Sec. 6.3.3. All the detritus variables can be grouped together with the following syntax:

```
#-----  
#      State Variable(s) for Detritus (Biogenic Organic Material)  
#-----  
group PelDetritus[cnpsf] (OMT) : mg C/m3 : mmol N/m3: mmol P/m3:  
                                mmol Si/m3 : umol Fe/m3  
R1[-s]      : Labile Dissolved Organic Matter  
R2[-npsf]   : Semi-labile Dissolved Organic Carbon  
R3[-npsf]   : Semi-refractory Dissolved Organic Carbon  
R6          : Particulate Organic Matter  
end
```

### 7.4. Example 3. Removing components from zooplankton

For certain purposes it is not needed to carry out the computation of variable nutrient:carbon quota in selected Functional Groups (for instance, in the case of the new macrozooplankton group added in example 1). This can be done to save computational resources in the case of low-resolution long-term global ocean simulations or with high-resolution coastal models. A possible example is the assumption of a fixed quota in zooplankton which allows one to reduce the number of standard components of up to 8 state variables. The zooplankton group definitions are equal to the one shown in the code of Box 7.1 for MesoZooPlankton but with the removal of the n and p constituents:

```
#-----  
#      State Variable(s) for MesoZooPlankton  
#-----  
group MesoZooPlankton[cnp] (MEZ) : mg C/m3 : mmol N/m3 : mmol P/m3  
                                Z3[-np]      : Carnivorous MesoZooPlankton  
                                Z4[-np]      : Omnivorous MesoZooPlankton  
end
```

The additional requirement is the change of value in parameter `check_fixed_quota` from 0 to 1 in the `Param_parameters` namelist. Test experiments have shown that the simulation times can be reduced up to 30%. The physiological assumption is that zooplankton release in inorganic form the nutrients in excess of the given fixed quota.

## 7. *Design model layout components*



## 8. Model outputs

### 8.1. Output

The variables that can be stored in the output file are the ones defined in file `layout`. All the state variables can be stored (provided that they have a long name and units), both as instantaneous values and as means over the chosen output period. This behavior is controlled via the namelist `bfm_save_nml` contained in the `BFM_General.nml` file when running the STANDALONE model. Other couplings may have different names. Additionally, a set of other variables can be saved, such as the ones obtained from the physical model and other diagnostics such as total chlorophyll, nutrient quota or aggregated rates.

### 8.2. Restart

The length of each BFM simulation is controlled by the physical transport model except for the STANDALONE model which has its own time marching. It is common practice in modeling to split the simulation in several chunks and to continue the simulation from the end values of each state variable at the end of a previous run. The BFM stores this information in a NetCDF file which is always generated at the end of each simulation. There is no automatic control on the date (neither it is stored as an attribute inside the NetCDF file), so it is totally up to the user to check that the initial restart file is the proper one. The input/output restart file names and the restart switch (`bfm_init`) are set in the `BFM_General.nml` file within the namelist `bfm_init_nml`.

### 8.3. Aggregated diagnostics and rates

All the ancillary 2D and 3D variables (like wind velocity or temperature, for instance) and diagnostics are grouped in two memory arrays, `D3DIAGNOS` and `D2DIAGNOS`, which are accessed by means of pointers. The dimensions of these arrays change according to the number of model elements in the `layout` file, and any diagnostic rate can be easily defined thanks to the automatic generation of the memory layout. Some fluxes are already defined by default, such as the gross/net primary production rates, total respiration rates and (de)nitrification rates.

Any exchange of mass between every state variable can be tracked by means of a special syntax that allows the user to access and combine the elements of the `D3(D2)SOURCE` and `D3(D2)SINK` arrays where all the rates are stored. Some examples are already included at the end of the `STANDALONE_PELAGIC/layout` file and are activated with the compilation macros `INCLUDE_DIAG`:

```
#
```

```
-----
```

```
#
```

```
DIAGNOSTIC RATES
```

## 8. Model outputs

```
#
-----

3d-flux -if-exist INCLUDE_DIAG INCLUDE_PELCO2
  ruPPYc=P.c <- O3c : Gross Primary Production : mg C/m3/d
  resPPYc=P.c -> O3c : Phytoplankton Respiration : mg C/m3/d
  resPBAC=B.c -> O3c : Bacterial Respiration : mg C/m3/d
  resZOOc=Z.c -> O3c : Zooplankton Respiration : mg C/m3/d
end

3d-flux -if-exist INCLUDE_DIAG
  ruPPYn=P.n <- N3n+N4n: Net Nitrogen Uptake:mmol N/m3/d
  ruPPYp=P.p <- N1p : Net Phosphate Uptake : mmol P/m3/d
  ruPPYs=P.s <- N5s : Net Silicate Uptake : mmol Si/m3/d
  exPPYc=(P.c->R1c+R2c+R3c+R6c): C excretion from phytoplankton :mg C/m3/
    d
  ruZOOc=(Z.c<-P.c+B.c+Z.c): Gross Secondary Production:mg C/m3/d
  resPELo=(O2o->*) : Pelagic Oxygen Demand : mmol O2/m3/d
  remZOO n=(N4n<-B.n+Z.n): Zooplankton N Remineralization : mmol N/m3/d
  remZOO p=(N1p<-B.p+Z.p): Zooplankton P Remineralization : mmol P/m3/d
  remPBAn=(N4n<-B.n): Bacterial N Uptake/Remineralization : mmol N/m3/d
  remPBAp=(N1p<-B.p): bacterial P Uptake/Remineralization : mmol P/m3/d
end
```

The names used for the diagnostics are derived from the short names of the groups defined above in the layout file (see Sec. 7), preceded by the letter *r* for rate and the identifier of the chemical constituent. This is not mandatory, but it is suggested to follow the convention derived from the original ERSEM code (Blackford and Radford, 1995) to easily identify the type of rate. The first line, for instance, defines the combined rate of gross primary production *ruPPYc* (rate of uptake of pelagic phytoplankton *PPY* expressed in carbon), which is the sum of all the carbon fluxes to all the phytoplankton groups (notice the syntax using the wildcard “.” to indicate all sub-groups).

An example of aggregated flux is the carbon excretion from phytoplankton *exPPYc* or gross secondary production *ruZOOc*, which is defined as the sum of carbon ingestion by all zooplankton groups. The diagnostics also define the *long\_name* and *units* attributes for the NetCDF output. Diagnostics can be included in the output just by adding the name to the *bfm\_save\_nml* namelist in *BFM\_General.nml*.

Boundary fluxes are defined by default for each pelagic state variable. The variables

```
PELSURFACE(NO_D3_BOX_STATES,NO_BOXES_XY)
PELBOTTOM(NO_D3_BOX_STATES,NO_BOXES_XY)
```

are also pointers to the main diagnostic memory *D2DIAGNOS* and store the surface and bottom boundary flux for any state variable. They can be accessed by means of specific pointers allocated in the generated subroutine *BFM/General/AllocateMem.F90* (notice that the integer constants change at every code generation and are only reported here as an example of the code):

```
PELSURFACE => D2DIAGNOS(17+1:17+50, :); PELSURFACE=ZERO
jsurO2o => D2DIAGNOS(17+ppO2o, :); jsurO2o=ZERO
jsurN1p => D2DIAGNOS(17+ppN1p, :); jsurN1p=ZERO
jsurN3n => D2DIAGNOS(17+ppN3n, :); jsurN3n=ZERO
jsurN4n => D2DIAGNOS(17+ppN4n, :); jsurN4n=ZERO
```

The boundary rates (always in units per day) are accessed in the code by means of both the direct

value `PELSURFACE (ppO2o, :)` or the pointer `jsurO2o (:)`, but can be added to the output in the `bfm_save_nml` section of `BFM_General.nml` only with the pointer name (e.g. `jsurO2o`).

### 8.4. Mass conservation

The total mass in the system (mass units  $\text{m}^{-2}$ ) can be checked by means of built-in diagnostic variables. There is a variable for each biogeochemical component (C, N, P, Si, etc.) both for the pelagic and the benthic systems. To activate the diagnostic it is necessary to add the following lines to the output namelist in the `var_save` section:

```
var_save = 'totpeln',  
          'totpelp',  
          'totpels'
```

The actual computation is done in `General/CheckMassConservation.F90`. Note that for technical reasons the total mass variables are multidimensional but the value is stored in the first element of the array. When checking a coupling with an OGCM, it is also important to turn off any additional boundary flux (e.g. dilution, atmospheric deposition, river input, etc.) because they are not taken into account by the standard BFM.

## 8. *Model outputs*

# Bibliography

- Andersen, T., Elser, J. J., Hessen, D. O., 2004. Stoichiometry and population dynamics. *Ecol. Lett.* 7, 884–900.
- Anderson, T. R., 2005. Plankton functional type modelling: running before we can walk? *J. Plankt. Res.* 27, 1073–1081.
- Archer, D. E., Johnson, K. S., 2000. A Model of the iron cycle in the ocean. *Glob. Biogeochem. Cy.* 14, 269–279.
- Arrigo, K. R., Dieckmann, G., Gosselin, M., Robinson, D. H., Fritsen, C. H., Sullivan, C. W., 1995. High resolution study of the platelet ice ecosystem in McMurdo Sound, Antarctica: biomass, nutrient, and production profiles within a dense microalgal bloom. *Mar. Ecol. Prog. Ser.* 127, 255–268.
- Aumont, O., Maier-Reimer, E., Monfray, P., Blain, S., 2003. An ecosystem model of the global ocean including Fe, Si, P co-limitations. *Glob. Biogeochem. Cy.* 17 (2), 1060.
- Baretta, J., Ebenhöf, W., Ruardij, P., 1995. The European Regional Seas Ecosystem Model, a complex marine ecosystem model. *J. Sea Res.* 33 (3-4), 233–246.
- Baretta-Bekker, J., Baretta, J., Ebenhöf, W., 1997. Microbial dynamics in the marine ecosystem model ERSEM II with decoupled carbon assimilation and nutrient uptake. *J. Sea Res.* 38 (3/4), 195–212.
- Baretta-Bekker, J., Baretta, J., Rasmussen, E., 1995. The microbial food web in the European Regional Seas Ecosystem Model. *J. Sea Res.* 33 (3-4), 363–379.
- Behrenfeld, M. J., Prasil, O., Babin, M., Bruyant, F., 2004. In search of a physiological basis for covariations in light-limited and light-saturated photosynthesis. *J. Phycol.* 40, 4–25.
- Berline, L., Stemmann, L., Vichi, M., Lombard, F., Gorsky, G., 06 2011. Impact of appendicularians on detritus and export fluxes: a model approach at dyfamed site. *J. Plankt. Res.* 33 (6), 855–872.
- Bidle, K. D., Azam, F., 2001. Bacterial control of silicon regeneration from diatom detritus: Significance of bacterial ectohydrolases and species identity. *Limnol. Oceanogr.* 46 (7), 1606–1623.
- Blackford, J., Radford, P., 1995. A structure and methodology for marine ecosystem modelling. *J. Sea Res.* 33 (3-4), 247–260.
- Blackford, J. C., Allen, J. I., Gilbert, F. J., 2004. Ecosystem dynamics at six contrasting sites: a generic modelling study. *J. Mar. Sys.* 52, 191–215.
- Blackford, J. C., Burkill, P. H., 2002. Planktonic community structure and carbon cycling in the Arabian Sea as a result of monsoonal forcing: the application of a generic model. *J. Mar. Sys.* 36 (3), 239–267.
- Broekhuizen, N., Heath, M., Hay, S., Gurney, W., 1995. Modelling the dynamics of the North Sea's mesozooplankton. *J. Sea Res.* 33 (3-4), 381–406.
- Contois, D., 1959. Kinetics of bacterial growth: relationship between population density and specific growth rate of continuous cultures. *Journal of general microbiology* 21 (1), 40–50.
- Cota, G. F., Legendre, L., Gosselin, M., Ingram, R. G., 1991. Ecology of bottom ice algae: I Environmental controls and variability. *J. Mar. Syst.* 2, 257–277.

## Bibliography

- Dieckmann, G. S., Lange, M. A., Ackley, S. F., Jennings, J. C., 1991. The Nutrient Status in Sea Ice of the Weddell Sea During Winter: Effects of Sea Ice Texture and Algae. *Polar Biology* 11, 449–456.
- Doney, S. C., Lindsay, K., Caldeira, K., Campin, J. M., Drange, H., Dutay, J. C., Follows, M., Gao, Y., Gnanadesikan, A., Gruber, N., Ishida, A., Joos, F., Madec, G., Maier-reimer, E., Marshall, J. C., Matear, R. J., Monfray, P., Mouchet, A., Najjar, R., Orr, J. C., Plattner, G. K., Sarmiento, J., Schlitzer, R., Slater, R., Totterdell, I. J., Weirig, M. F., Yamanaka, Y., Yool, A., 2004. Evaluating global ocean carbon models: The importance of realistic physics. *Glob. Biogeochem. Cy.* 18, 3017.
- Droop, M., 1973. Some thoughts on nutrient limitation in algae. *J. Phycol.* 9, 264–272.
- Ebenhöh, W., Baretta-Bekker, J., Baretta, J., 1997. The primary production module in the marine ecosystem model ERSEM II with emphasis on the light forcing. *J. Sea Res.* 38, 173–193.
- Flynn, K. J., 2003. Modelling multi-nutrient interactions in phytoplankton; balancing simplicity and realism. *Prog. Oceanogr.* 56 (2), 249–279.
- Flynn, K. J., Marshall, H., Geider, R. J., 2001. A comparison of two N-irradiance interaction models of phytoplankton growth. *Limnol. Oceanogr.* 46, 1794–1802.
- Follows, M. J., Ito, T., Dutkiewicz, S., 2006. On the solution of the carbonate chemistry system in ocean biogeochemistry models. *Ocean Modelling* 12 (3-4), 290–301.
- Frost, P. C., Xenopoulos, M. A., Larson, J. H., 2004. The stoichiometry of dissolved organic carbon, nitrogen, and phosphorus release by a planktonic grazer, *Daphnia*. *Limnol. Oceanogr.* 49, 1802–1808.
- Geider, R., MacIntyre, H., Kana, T., 1996. A dynamic model of photoadaptation in phytoplankton. *Limnol. Oceanogr.* 41 (1), 1–15.
- Geider, R., MacIntyre, H., Kana, T., 1997. A dynamic model of phytoplankton growth and acclimation: responses of the balanced growth rate and chlorophyll *a*:carbon ratio to light, nutrient limitation and temperature. *Mar. Ecol. Prog. Ser.* 148, 187–200.
- Geider, R., MacIntyre, H., Kana, T., 1998. A dynamic regulatory model of phytoplanktonic acclimation to light, nutrients, and temperature. *Limnol. Oceanogr.* 43 (3), 679–694.
- Gentleman, W., Leising, A., Frost, B., Strom, S., Murray, J., 2003. Functional responses for zooplankton feeding on multiple resources: a review of assumptions and biological dynamics. *Deep-Sea Res. Pt. II* 50, 2847–2875.
- Gibson, G. A., Musgrave, D. L., Hinckley, S., 2005. Non-linear dynamics of a pelagic ecosystem model with multiple predator and prey types. *J. Plankt. Res.* 27, 427–447.
- Goldman, J., McCarthy, J., 1978. Steady state growth and ammonium uptake of a fast-growing marine diatom. *Limnology and oceanography* 23 (4), 695–703.
- Gosselin, M., Legendre, L., Demers, S., Ingram, R. G., 1985. Responses of Sea-Ice Microalgae to Climatic and Fortnightly Tidal Energy Inputs (Manitounuk Sound, Hudson Bay). *Canadian Journal of Fisheries and Aquatic Sciences* 42, 5, 999–1006, doi:10.1139/CJFAS-42-5-999.
- Granskog, M. A., Kaartokallio, H., Kuosa, H., Thomas, D. N., Vainio, J., 2006. Sea ice in the baltic sea: A review. *Estuarine, Coastal and Shelf Science* 70, 145–160.
- Heissenberger, A., Leppard, G. G., Herndl, G. J., 1996. Relationship between the intracellular integrity and the morphology of the capsular envelope in attached and free-living marine bacteria. *Applied and environmental microbiology* 62 (12), 4521–4528.

- Jassby, A., Platt, T., 1976. Mathematical formulation of the relationship between photosynthesis and light for phytoplankton. *Limnol. Oceanogr.* 21, 540–547.
- Johnson, K. S., Gordon, R. M., Coale, K. H., 1997. What controls dissolved iron concentrations in the world ocean? *Mar. Chem.* 57, 137–161.
- Lazzari, P., Solidoro, C., Ibello, V., Salon, S., Teruzzi, A., Béranger, K., Colella, S., Crise, A., 2012. Seasonal and inter-annual variability of plankton chlorophyll and primary production in the mediterranean sea: a modelling approach. *Biogeosciences* 9 (1), 217–233.
- Lefevre, N., Watson, A. J., 1999. Modeling the geochemical cycle of iron in the oceans and its impact on atmospheric CO<sub>2</sub> concentrations. *Global Biogeochem Cy* 13, 727–736.
- Legendre, L., Ackley, S. F., Dieckmann, G. S., Gulliksen, B., Horner, R., Hoshiai, T., Melnikov, I. A., Reeburgh, W. S., Spindler, M., Sullivan, C. W., 1992. Ecology of sea ice biota: 2. global significance. *Polar Biology* 12, 429–444.
- Lengaigne, M., Menkes, C., Aumont, O., Gorgues, T., Bopp, L., Madec, J.-M. A. G., 2007. Bio-physical feedbacks on the tropical pacific climate in a coupled general circulation model. *Clim. Dyn.* 28, 503–516.
- Lizotte, M. P., Sullivan, C. W., 1991. Photosynthesis-irradiance relationships in microalgae associated with Antarctic pack ice: evidence for in situ activity. *Mar. Ecol. Prog. Ser.* 71, 175–184.
- Mitra, A., Flynn, K. J., 2005. Predator-prey interactions: is 'ecological stoichiometry' sufficient when good food goes bad? *J. Plankt. Res.* 27, 393–399.
- Morel, A., 1988. Optical modeling of the upper ocean in relation to its biogenous matter content (case i waters). *J. Geophys. Res.* 93, 10,749–10,768.
- Morel, F., 1987. Kinetics of uptake and growth in phytoplankton. *J. Phycol.* 23, 137–150.
- Olsen, A., Wanninkhof, R., Trinanes, J. A., Johannessen, T., 2005. The effect of wind speed products and wind speed-gas exchange relationships on interannual variability of the air-sea CO<sub>2</sub> gas transfer velocity. *Tellus B* 57, 95–106.
- Parekh, P., Follows, M. J., Boyle, E., 2004. Modeling the global ocean iron cycle. *Glob. Biogeochem. Cy.* 18, GB1002.
- Polimene, L., Allen, J. I., Zavatarelli, M., Jun 2006. Model of interactions between dissolved organic carbon and bacteria in marine systems. *Aquat. Microb. Ecol.* 43 (2), 127–138.
- Reinart, A., Arst, H., Blanco-Sequeiros, A., Herlevi, A., 1998. Relation between underwater irradiance and quantum irradiance in dependence on water transparency at different depths in the water bodies. *J. Geophys. Res.* 103 (C4), 7759–7752.
- Ruardij, P., Van Raaphorst, W., 1995. Benthic nutrient regeneration in the ERSEM ecosystem model of the North Sea. *J. Sea Res.* 33 (3-4), 453–483.
- Sakshaug, E., Bricaud, A., Dandonneau, Y., Falkowski, P. G., Kiefer, D. A., Legendre, L., Morel, A., Parslow, J., Takahashi, M., 1997. Parameters of photosynthesis: definitions, theory and interpretation of results. *J. Plankt. Res.* 19, 1637–1670.
- Stoderegger, K., Herndl, G., 1998. Production and release of bacterial capsular material and its subsequent utilization by marine bacterioplankton. *Limnol. Oceanogr.* 43 (5), 877–884.
- Sunda, W. G., Huntsman, S. A., 1997. Interrelated influence of iron, light and cell size on marine phytoplankton growth. *Nature* 390, 389–392.
- Tedesco, L., Vichi, M., 2010. BFM-SI: A new implementation of the biogeochemical flux model in sea ice. *Research Papers* 81, CMCC.

## Bibliography

- Tedesco, L., Vichi, M., 2014. Sea ice biogeochemistry: A guide for modellers. *PLoS ONE* 9(2) (e89217).
- Tedesco, L., Vichi, M., Haapala, J., Stipa, T., 2009. An enhanced sea-ice thermodynamic model applied to the Baltic Sea. *Boreal Environmental Research* 14, 68–80.
- Tedesco, L., Vichi, M., Haapala, J., Stipa, T., 2010. A dynamic biologically-active layer for numerical studies of the sea ice ecosystem. *Ocean Modelling* 35, 89–104.
- Tedesco, L., Vichi, M., Thomas, D. N., 2012. Process studies on the ecological coupling between sea ice algae and phytoplankton. *Ecol. Mod.* 226, 120–138.
- Thomas, D., Dieckmann, G., 2002. Antarctic sea ice - a habitat for extremophiles. *Science* 295, 5555, 641–644.
- Tsiaras, K. P., Kourafalou, V. H., Davidov, A., Staneva, J., 2008. A three-dimensional coupled model of the western black sea plankton dynamics: Seasonal variability and comparison to seawifs data. *J. Geophys. Res.* 113 (C7), C07007.
- Varela, R., Cruzado, A., Gabaldon, J., 1995. Modelling primary production in the North Sea using the European Regional Seas Ecosystem Model. *J. Sea Res.* 33 (3-4), 337–361.
- Vichi, M., Lovato, T., Gutierrez Mlot, E., McKiver, W., April 2015. Coupling BFM with ocean models: the NEMO model (Nucleus for the European Modelling of the Ocean). Release 1.0. BFM Report Series 2, Bologna, Italy. URL <http://bfm-community.eu>
- Vichi, M., Masina, S., 11 2009. Skill assessment of the PELAGOS global ocean biogeochemistry model over the period 1980-2000. *Biogeosciences* 6 (11), 2333–2353.
- Vichi, M., Masina, S., Navarra, A., 2007a. A generalized model of pelagic biogeochemistry for the global ocean ecosystem. Part II: numerical simulations. *J. Mar. Sys.* 64, 110–134.
- Vichi, M., Pinardi, N., Masina, S., 2007b. A generalized model of pelagic biogeochemistry for the global ocean ecosystem. Part I: theory. *J. Mar. Sys.* 64, 89–109.
- Vichi, M., Ruardij, P., Baretta, J. W., 2004. Link or sink: a modelling interpretation of the open Baltic biogeochemistry. *Biogeosciences* 1, 79–100.
- Wolf-Gladrow, D. A., Zeebe, R. E., Klaas, C., Körtzinger, A., Dickson, A. G., 2007. Total alkalinity: The explicit conservative expression and its application to biogeochemical processes. *Marine chemistry* 106 (1), 287–300.
- Worden, A. Z., Nolan, J. K., Palenik, B., 2004. Assessing the dynamics and ecology of marine picophytoplankton: The importance of the eukaryotic component. *Limnol. Oceanogr.* 49, 168–179.
- Zeebe, R. E., Wolf-Gladrow, D. A., 2001. *CO<sub>2</sub> in Seawater: Equilibrium, Kinetics, Isotopes*. Vol. 65 of Oceanography Book Series. Elsevier, Amsterdam.